

**AGENDA**  
**EAST GOSHEN TOWNSHIP**  
**BOARD OF SUPERVISORS**  
**1580 Paoli Pike, 2<sup>nd</sup> Floor**  
Tuesday, June 2, 2026  
7:00 PM

To Join Zoom Meeting:

**Link:** Register in advance for this meeting:

[https://us02web.zoom.us/join/register/52SJ94\\_4TXax74NLXHfjDw](https://us02web.zoom.us/join/register/52SJ94_4TXax74NLXHfjDw)

**During this *hybrid* BOS meeting, public comment will be handled as follows:**

- The Zoom public is asked to remain muted during the meeting when the Board is talking.
  - If you do not wish to be seen on the Board Room TVs or the YouTube Recording, your camera must be turned off via Zoom.
  - In-person public participants will be given the ***first*** opportunity to comment and ask questions on each agenda item that requires a Board vote.
  - The Zoom public participants will be given the ***second*** opportunity to comment and ask questions on each agenda item that requires a Board vote.
    - Zoom participants wishing to comment must raise their hand icon, state their name, and must speak one at a time.
1. Call to Order (7:00 PM)
  2. Pledge of Allegiance
  3. Moment of Silence  
Announce that this meeting is being recorded via Zoom. A recording will be uploaded later to the Township's YouTube channel for viewing.
  4. Chairman's Report
  5. Public Comment (7:05 PM to 7:15 PM)
  6. Emergency Services Reports (7:15 PM to 7:20 PM)
    - a. WEGO – Chief David Leahy
    - b. Goshen Fire Co – April 2026
    - c. Malvern Fire Co – April 2026
    - d. Good Fellowship – April 2026
  7. Public Hearings – None
  8. Financial Report –As of April 30, 2026 (7:20 PM to 7:25 PM)
  9. Approval of Minutes and Treasurer's Report (7:25 PM to 7:30 PM)
    - a. Minutes – None
    - b. Treasurer's Report – April 30, 2026 to May 28, 2026.
  10. Old Business - None
  11. New Business
    - a. Presentation by *PA Humanities* regarding the *PA Heart & Soul* program. (7:30 PM to 7:45 PM)
    - b. ESAC Pilot Composting Program discussion. (7:45 PM to 7:55 PM)
    - c. Discussion and possible approval of the 2026 Trash bid. (7:55 PM to 8:05 PM)
    - d. ESAC Solar Feasibility Study discussion. (8:05 PM to 8:15 PM)
    - e. Discussion and possible approval of Line Painting Bid. (8:15 PM to 8:20 PM)
    - f. Discussion and possible approval of Resolution 2026-08, disposal of record in accordance with the PHMC. (8:20 PM to 8:25 PM)

- g. Resolution 2026-09, approval of *Watershed Restoration & Protection* grant application. (8:25 PM to 8:30 PM)
  - h. Resolution 2020-10, Hicks Farm legal correction. (8:30 PM to 8:35 PM)
  - i. Discussion of ZHB application for dimensional variance – 17 Treemont Drive. (8:35 PM to 8:40 PM)
- 12. Any Other Matter (8:40 PM to 8:45 PM)
  - 13. Public Comment (8:45 PM to 8:55 PM)
  - 14. Liaison Reports (8:55 PM TO 9:00PM)
  - 15. Correspondence, Reports of Interest.
  - 16. Adjournment (9:00 PM)

**GOSHEN FIRE COMPANY  
APRIL 2026  
MONTHLY OPERATIONS REPORT  
FOR FIRE, EMS AND FIRE POLICE**



## SUMMARY

Fire calls are continuing to run well above last year, and year-to-date EMS calls are slightly lower than last year.

The Mother's Day Flower Sale at Station 56 was a success, with a great turnout by the community.

### Serious Incidents

Appliance Fire	902 Monte Vista Dr.	East Goshen	4/1
Dwelling Fire	543 Fernhill Lane	West Goshen	4/6
Dwelling Fire	1248 Hamilton Drive	West Goshen	4/16
MVA Entrapment	RT 202 SB MM 10.7	West Goshen	4/27

### Major Events & Fundraising

Mother's Day Flower Sale – Boot Road Station	May 8, 9, 10
Upcoming – America250 Event	May 30 <sup>th</sup>
Upcoming - Goshen Country Fair	July 27 <sup>th</sup> – August 1 <sup>st</sup>

## YEAR TO DATE SUMMARY

Fire Responses per Municipality	Monthly Responses	Monthly Manhours	YTD 2026 Responses	YTD 2026 Manhours	YTD 2025 Responses	YOY Variance
East Goshen	27	64	119	410	88	35%
West Goshen	19	64	100	241	62	61%
Westtown	11	71	33	120	31	6%
Willistown	3	4	21	41	12	75%
Other	7	24	47	247	19	147%
<b>Total - Fire</b>	<b>67</b>	<b>227</b>	<b>320</b>	<b>1059</b>	<b>212</b>	<b>51%</b>
Fire Police Responses per Municipality	Monthly Responses	Monthly Manhours	YTD 2026 Responses	YTD 2026 Manhours	YTD 2025 Responses	YOY Variance
East Goshen	6	12	27	92	25	8%
West Goshen	13	43	49	144	38	29%
Westtown	7	23	11	33	25	-56%
Willistown	1	3	7	36	18	-61%
Other	2	6	9	40	11	-18%
<b>Total - Fire Police</b>	<b>29</b>	<b>87</b>	<b>103</b>	<b>345</b>	<b>117</b>	<b>-12%</b>
EMS Responses per Municipality	Monthly Responses	Monthly Manhours	YTD 2026 Responses	YTD 2026 Manhours	YTD 2025 Responses	YOY Variance
East Goshen	188	325	788	1898	855	-8%
West Goshen	126	210	569	1172	473	20%
Westtown	39	58	140	292	132	6%
Willistown	15	27	115	284	177	-35%
Other	25	30	72	118	96	-25%
<b>Total - EMS</b>	<b>393</b>	<b>650</b>	<b>1684</b>	<b>3764</b>	<b>1733</b>	<b>-3%</b>
Total Responses per Municipality	Monthly Responses	Monthly Manhours	YTD 2026 Responses	YTD 2026 Manhours	YTD 2025 Responses	YOY Variance
East Goshen	221	401	934	2400	968	-4%
West Goshen	158	317	718	1557	573	25%
Westtown	57	152	184	445	188	-2%
Willistown	19	34	143	361	207	-31%
Other	34	60	128	405	126	2%
<b>Total - Goshen Fire Company</b>	<b>489</b>	<b>964</b>	<b>2107</b>	<b>5168</b>	<b>2062</b>	<b>2%</b>

Staff-Hours on Apparatus	Fire	EMS
Volunteer	139	4
Career	88	646

## Fire Response Data

### Calls by Incident Type - month

TYPE CALLS	APRIL	YTD
ACCIDENT - ALS	2	5
ACCIDENT - BLS	3	13
ACCIDENT - ENTRAPMENT	2	6
ACCIDENT - FIRE	1	4
ACCIDENT - PEDESTRIAN STRUCK	1	3
ACCIDENT - VEHICLE VS BLDG	1	1
ALARM - CARBON MONOXIDE	3	22
ALARM - GAS	0	2
ALARM - MEDICAL - BLS	0	1
ALARM FIRE	25	104
FIRE - APARTMENT BUILDING FIRE	1	3
FIRE - APPLIANCE FIRE	2	6
FIRE - ASSIST THE AMBULANCE	0	5
FIRE - BRUSH	1	5
FIRE - BUILDING	1	8
FIRE - CARBON MONOXIDE INCIDENT	0	2
FIRE - CHIMNEY	0	2
FIRE - FORCIBLE ENTRY	1	2
FIRE - FUEL SPILL	0	1
FIRE - GAS LEAK INSIDE	2	15
FIRE - GAS LEAK OUTSIDE	2	7
FIRE - HOUSE FIRE	4	21
FIRE - NOTIFY FIRE CHIEF	4	8
FIRE - ODOR INVESTIGATION INSIDE	2	9
FIRE - OUT BUILDING/SHED	0	1
FIRE - POLES,WIRES,TRANSFORMER FIRE	2	11
FIRE - PUBLIC SERVICE	1	7
FIRE - RELOCATE FIRE/EMS UNITS	1	2
FIRE - RESIDENTIAL RESCUE	1	2
FIRE - SMOKE/ODOR INVEST OUTSIDE	0	3
FIRE - STUCK/MALFUNCTIONING ELEVATOR	0	6
FIRE - TRASH/DUMPSTER FIRE	0	1
FIRE - VEHICLE	1	2
FIRE - ASSIST EMS	3	30

## EMS Response Data

<b>Total Calls</b>	393
--------------------	-----

<b>Calls to Assisted Living and Retirement Communities</b>	
Arbor Terrace Willistown	9
Bellingham	16
Bryn Mawr Rehab	1
Harrison Hill Apartments	1
Hershey's Mill	57
Merrill Gardens	22
Park Lane	12
Pembroke	28
Wellington	48

<b>Patients Treated</b>	
Patients Treated (Total)	314
Patients Treated - Age 65 and Over	231
	74%

<b>Transport Destination</b>	<b>TOTAL</b>
Bryn Mawr Hospital	0
Chester County Hospital	157
CHOP KOP	0
Nemours Childrens Hospital	0
Paoli Memorial Hospital	110
Riddle Memorial Hospital	0
<b>Total Patients transported</b>	267
<b>Calls with no transport</b>	127
	32%

<b>Patient Transfer Time</b>	
<b>Maximum (minutes)</b>	<b>91</b>

<b>Type Calls</b>	<b>#</b>
ACCIDENT-ALS	4
ACCIDENT-BLS	16
ACCIDENT-ENTRAPMENT	3
ACCIDENT-FIRE	1
ACCIDENT-PEDESTRIAN STRUCK	1
ACCIDENT-VEHICLE VS BLDG	1
ALARM-CARBON MONOXIDE	3
ALARM-FIRE	3
ALARM-MEDICAL - BLS	18
FIRE-APARTMENT BUILDING	1
FIRE-ELECTRICAL INSIDE	1
FIRE-FORCIBLE ENTRY	1
FIRE-GAS LEAK INSIDE	2
FIRE-HOUSE	4
FIRE-POLES,WIRES,TRANSFORMER	2
FIRE-RESIDENTIAL RESCUE	1
MEDICAL-ABDOMINAL PAIN - BLS	12
MEDICAL-ALLERGC/MED REACTION - ALS	2
MEDICAL-ALLERGC/MED REACTION - BLS	2
MEDICAL-ASSAULT W/ INJ (JO/IP) - ALS	1
MEDICAL-BACK PAIN - BLS	6
MEDICAL-CARDIAC/RESP ARREST - ALS	4
MEDICAL-CVA/STROKE - ALS	6
MEDICAL-DIABETIC EMERGENCY - ALS	4
MEDICAL-DOA - BLS	1
MEDICAL-EMOTIONAL DISORDER - BLS	5
MEDICAL-FALL / LIFT ASSIST - BLS	93
MEDICAL-FALLS - ALS	9
MEDICAL-HEART PROBLEMS - ALS	29
MEDICAL-HEMORRHAGING - ALS	7
MEDICAL-HEMORRHAGING - BLS	2
MEDICAL-HYPO TENSION - ALS	8
MEDICAL-INJURED PERSON - ALS	2
MEDICAL-INJURED PERSON - BLS	18
MEDICAL-OVERDOSE - ALS	3
MEDICAL-OVERDOSE - BLS	8
MEDICAL-RESPIRATORY DIFFICULTY - ALS	30
MEDICAL-SEIZURES - ALS	2
MEDICAL-SICK PERSON - BLS	57
MEDICAL-SYNCOPE - ALS	5
MEDICAL-UNCONSCIOUS PERSON - ALS	7
MEDICAL-UNKNOWN NATURE - BLS	2
MEDICAL-UNRESPONSIVE PERSON - ALS	6

## EMS Response Data, continued

ALS / BLS Dispatches and their dispositions	April	YTD
Dispatched as ALS	133	641
Transported as ALS	68	278
Transported as BLS	50	277
No Transport	15	86
Dispatched as BLS	260	1043
Transported as BLS	145	605
Transported as ALS	3	11
No Transport	112	427

Patients Treated By ALS Units (Total)	April	YTD
GFAC	61	223
MALVERN	8	60
MINQUAS	0	1
PAOLI	0	1
OTHER	2	4

Unit Statistics - Call Counts by Unit	April	YTD
A54-1	52	214
A54-2	0	5
A54-3	148	650
A56-1	130	596
A56-2	63	219

## Fire Police Response Data

	APRIL	YTD
<b>Total Calls</b>	<b>29</b>	<b>103</b>
<b>Hours In Service</b>	<b>20</b>	<b>85</b>
<b>Person Hours In Service</b>	<b>85</b>	<b>338</b>
<b>Calls 2 Hours or longer</b>	<b>0</b>	<b>9</b>

<b>Calls by Nature</b>	<b>MAR</b>	<b>YTD</b>
Appliance	1	3
Brush	0	4
Building	0	6
Chimney Fire	0	2
Dwelling	3	7
Electrical Fire Inside	1	1
Fire	0	1
Fuel Spill	0	1
Gas Leak	2	6
MVA	19	59
Pedestrian Struck	0	2
Special Duty	1	1
Traffic Control Assist	0	1
Trash	0	1
Trees & Wires	1	6
Vehicle Fire	1	2

# CHARTS

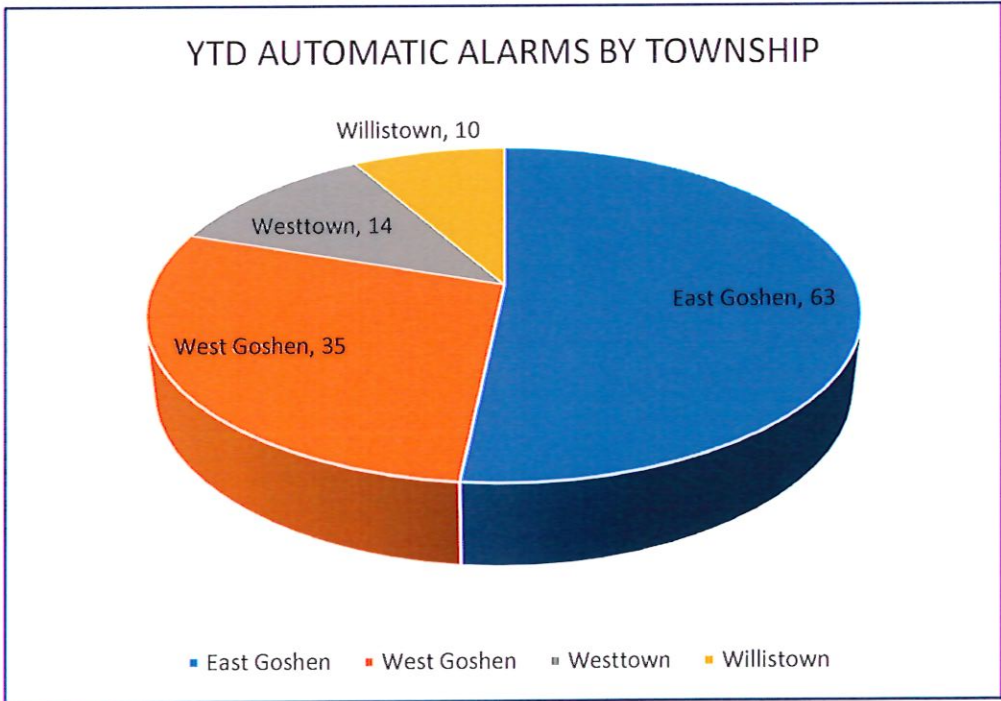
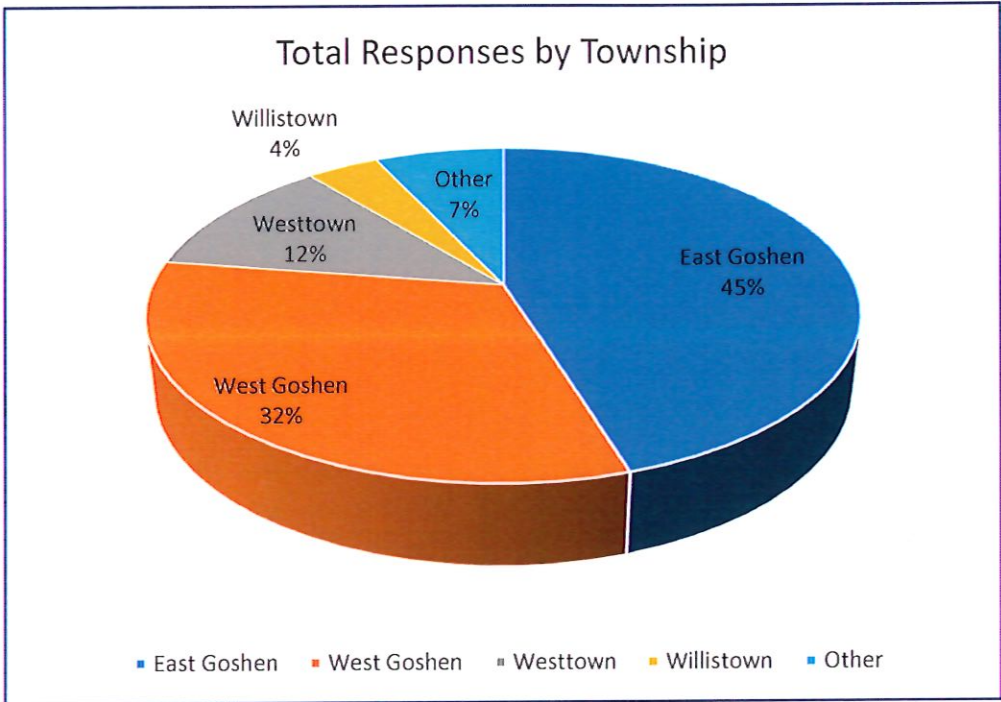

# 2026 GOSHEN FIRE COMPANY AUTOMATIC ALARM REPORT

*Addresses With More Than 1 Alarm Year-to-Date*

INCIDENT LOCATION	Jan	Feb	Mar	Apr	May	Jun	Jul	Aug	Sep	Oct	Nov	Dec	YTD
1361 BOOT RD EAST GOSHEN TOWNSHIP PA	3												3
1373 ENTERPRISE DR EAST GOSHEN TOWNSHIP PA				2									2
1515 MANLEY RD EAST GOSHEN TOWNSHIP PA		5											5
1600 RAEWYCK DR EAST GOSHEN TOWNSHIP PA			1	1									2
1604 PAOLI PIKE EAST GOSHEN TOWNSHIP PA		2											2
1615 E BOOT RD EAST GOSHEN TOWNSHIP PA	3	2	3	2									10
1716 CLOCKTOWER DR EAST GOSHEN TOWNSHIP PA	1			1									2
206 APPLEBROOK DR EAST GOSHEN TOWNSHIP PA			2										2
1030 ANDREW DR WEST GOSHEN TOWNSHIP PA		2											2
1130 WEST CHESTER PIKE WEST GOSHEN TOWNSHIP PA		3	2										5
200 LAWRENCE DR WEST GOSHEN TOWNSHIP PA		1	1										2
500 ELLIS LN WEST GOSHEN TOWNSHIP PA	2			1									3
1309 HALIFAX CT WESTTOWN TOWNSHIP PA	2												2
1502 WEST CHESTER PIKE WESTTOWN TOWNSHIP PA	1	1											2
944 GARRETT MILL RD WILLISTOWN TOWNSHIP PA	1	1											2

# Malvern Fire Company EMS Monthly Report



April 2026



Malvern Fire Company  
 Emergency Medical Service  
 April 2026 Monthly Report

**April 2026 Total Responses: 210**

**April 2025 Total Responses: 202**

**2026 Year-to-date Total Responses: 828**

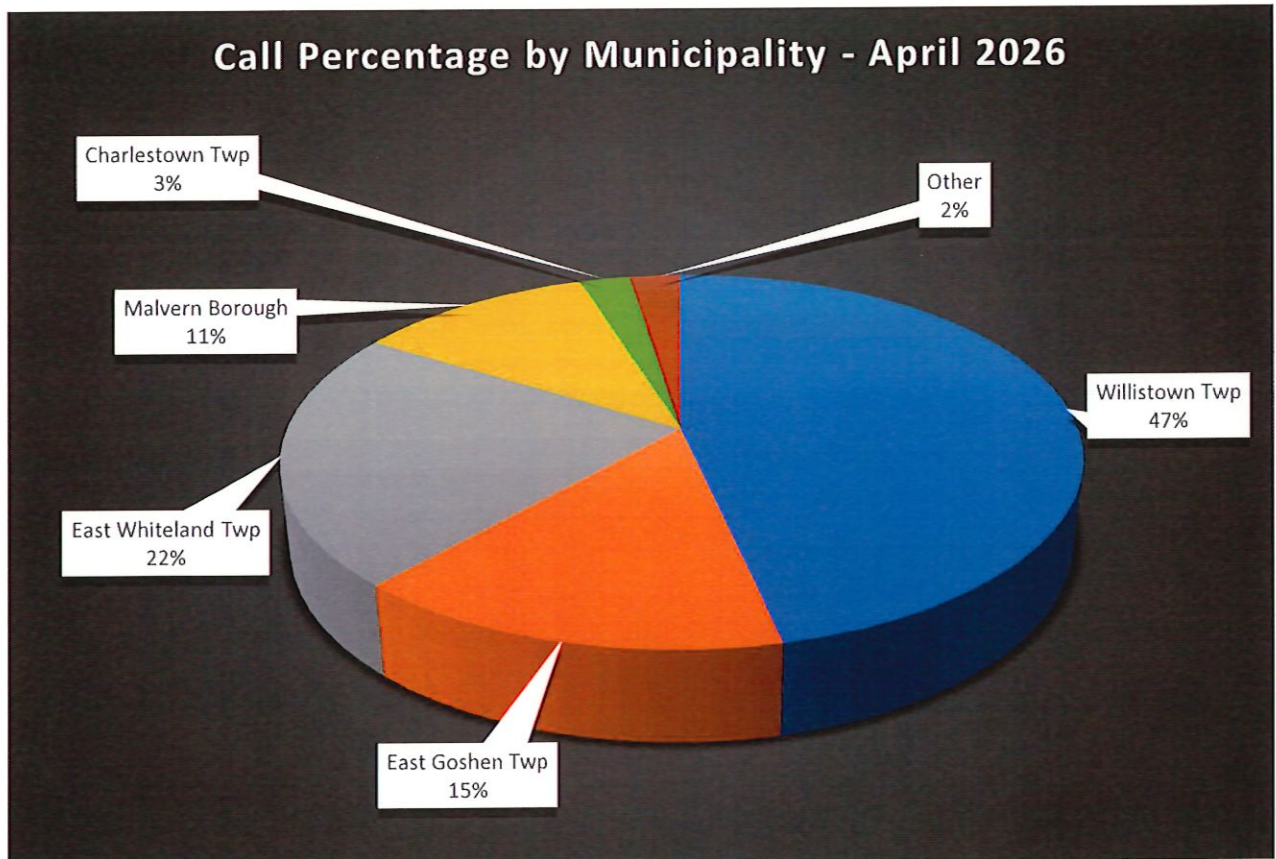

Municipality	Monthly Responses	YTD Responses	YTD %
<a href="#">Willistown Twp</a>	91	377	45.5%
<a href="#">East Whiteland Twp</a>	39	154	18.6%
<a href="#">East Goshen Twp</a>	30	153	18.5%
<a href="#">Malvern Borough</a>	35	99	12.0%
<a href="#">Charlestown Twp</a>	1	15	1.8%
<a href="#">Other</a>	14	30	3.6%
<b>Total</b>	<b>210</b>	<b>828</b>	<b>100.0%</b>



Malvern Fire Company  
 Emergency Medical Service  
 April 2026 Monthly Report



### Calls by Fire Local:

Fire Company	Month	YTD	YTD %
Malvern Fire Company	113	403	48.7%
East Whiteland Fire Company	40	156	18.8%
Goshen Fire Company	27	150	18.1%
Paoli Fire Company	22	90	10.9%
Kimberton Fire Company	1	15	1.8%
Other	7	14	1.7%
<b>Total</b>	<b>210</b>	<b>828</b>	<b>100%</b>

# Malvern Fire Company EMS Monthly Report



March 2026



Malvern Fire Company  
 Emergency Medical Service  
 March 2026 Monthly Report

**March 2026 Total Responses: 206**

**March 2025 Total Responses: 190**

**2026 Year-to-date Total Responses: 618**

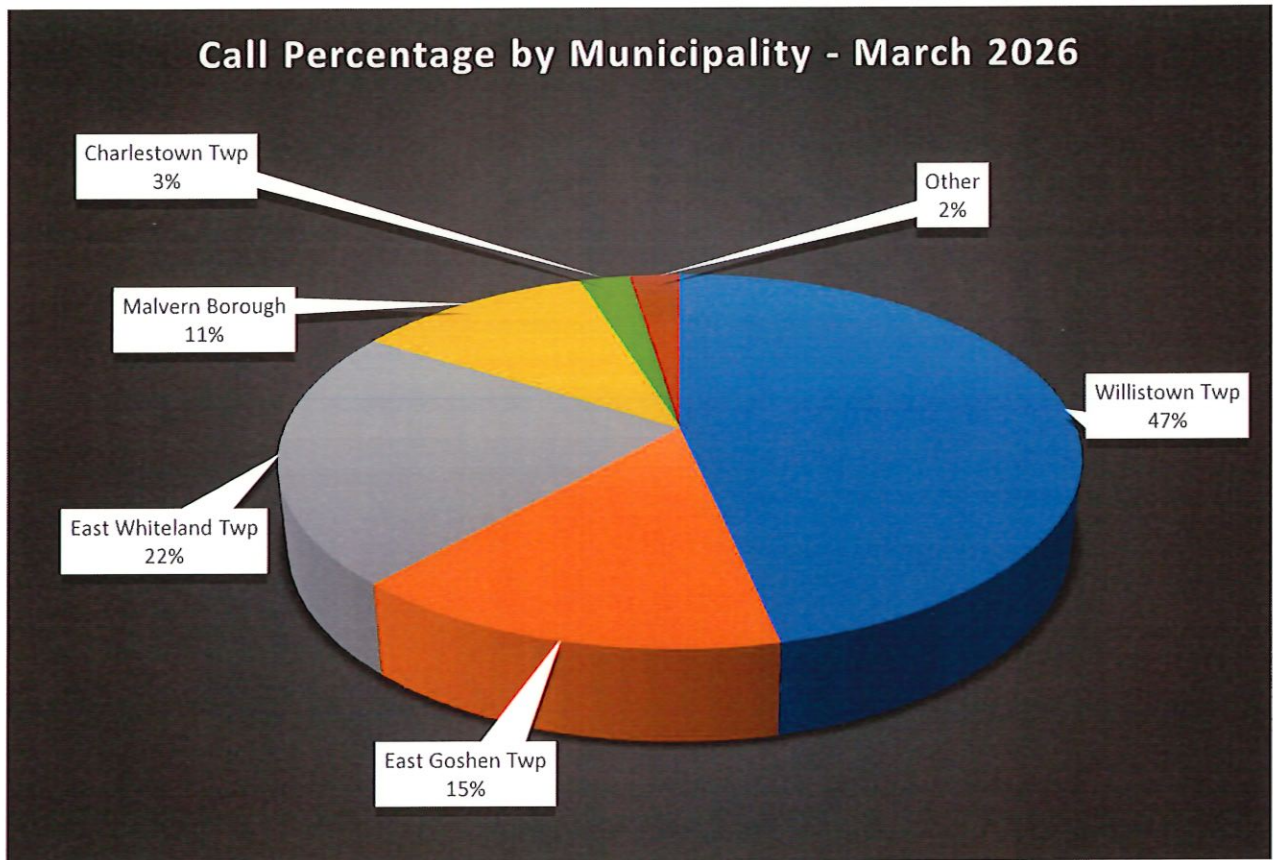

Municipality	Monthly Responses	YTD Responses	YTD %
<a href="#">Willistown Twp</a>	96	286	46.3%
<a href="#">East Whiteland Twp</a>	46	115	18.6%
<a href="#">East Goshen Twp</a>	31	123	19.9%
<a href="#">Malvern Borough</a>	23	64	10.4%
<a href="#">Charlestown Twp</a>	5	14	2.3%
<a href="#">Other</a>	5	16	2.6%
<b>Total</b>	<b>206</b>	<b>618</b>	<b>100.0%</b>



Malvern Fire Company  
 Emergency Medical Service  
 March 2026 Monthly Report

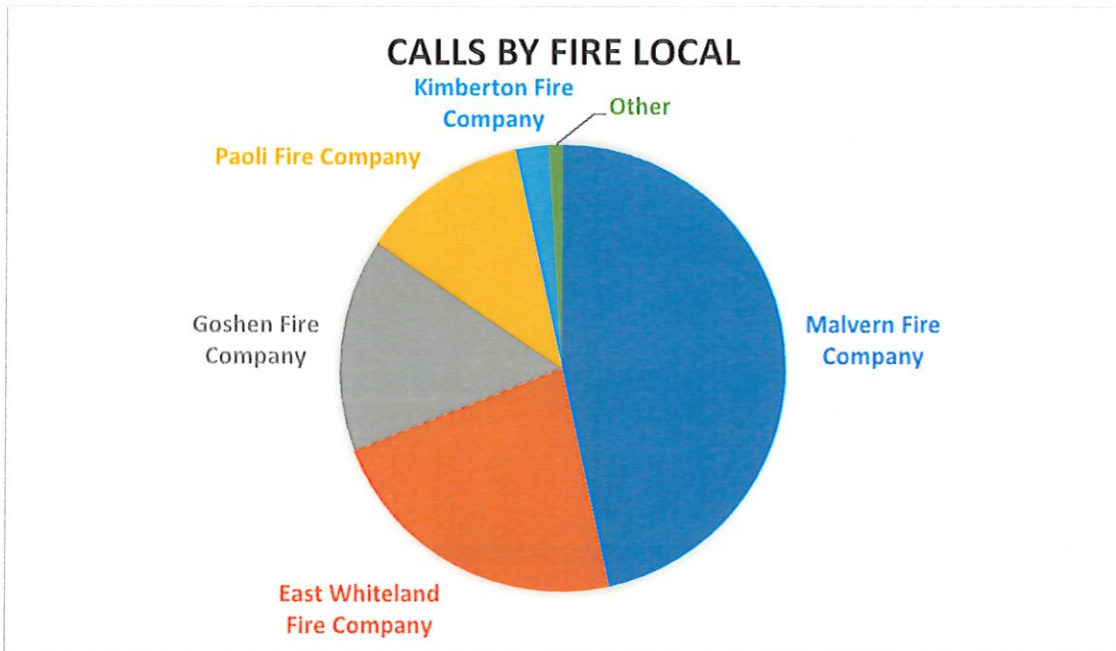

### Calls by Fire Local:

Fire Company	Month	YTD	YTD %
Malvern Fire Company	96	290	46.9%
East Whiteland Fire Company	46	116	18.8%
Goshen Fire Company	32	123	19.9%
Paoli Fire Company	25	68	11.0%
Kimberton Fire Company	5	14	2.3%
Other	2	7	1.1%
<b>Total</b>	<b>206</b>	<b>618</b>	<b>100%</b>



# April 2026

## EAST GOSHEN TOWNSHIP

	2025	2026	YOY Variance
JAN	74	68	-8%
FEB	60	52	-13%
MAR	62	59	-5%
APR	66	53	-20%
MAY	48		
JUN	75		
JUL	71		
AUG	74		
SEP	47		
OCT	59		
NOV	56		
DEC	72		
	<b>764</b>	<b>232</b>	Year Avg: <b>-11.5%</b>



*April 2026*  
**OPERATIONS REPORT**

## CALL VOLUME

Municipality	Month	% of Calls	YTD
West Chester	219	27.1%	790
West Whiteland	178	22.0%	767
West Goshen	119	14.7%	551
East Bradford	76	9.4%	273
Westtown	62	7.7%	257
East Goshen	53	6.6%	232
West Bradford	26	3.2%	107
Thornbury	10	1.2%	57
Birmingham	8	1.0%	28
Newlin	4	0.5%	15
East Whiteland	12	1.5%	
Downingtown	11	1.4%	
Uwchlan	7	0.9%	
Upper Uwchlan	6	0.7%	
East Caln	5	0.6%	
Caln	4	0.5%	
West Vincent	2	0.2%	
Coatesville	1	0.1%	
East Marlborough	1	0.1%	
Easttown	1	0.1%	
Pennsbury	1	0.1%	
Pocopson	1	0.1%	
West Pikeland	1	0.1%	
	808		

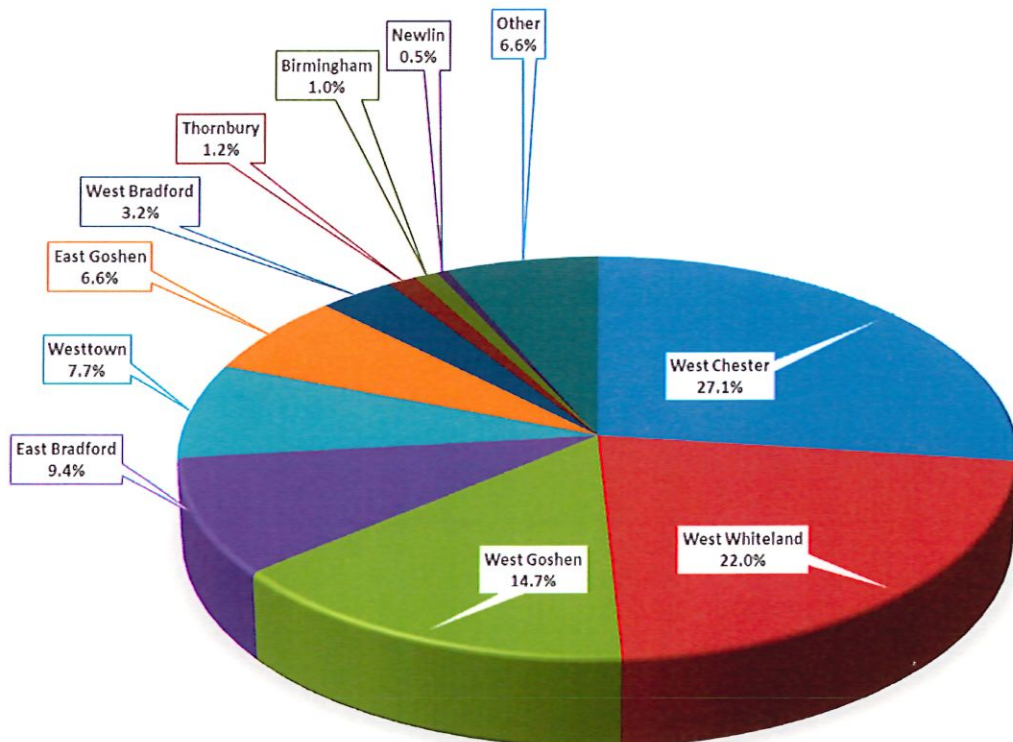

### Call Volume By Day of Week

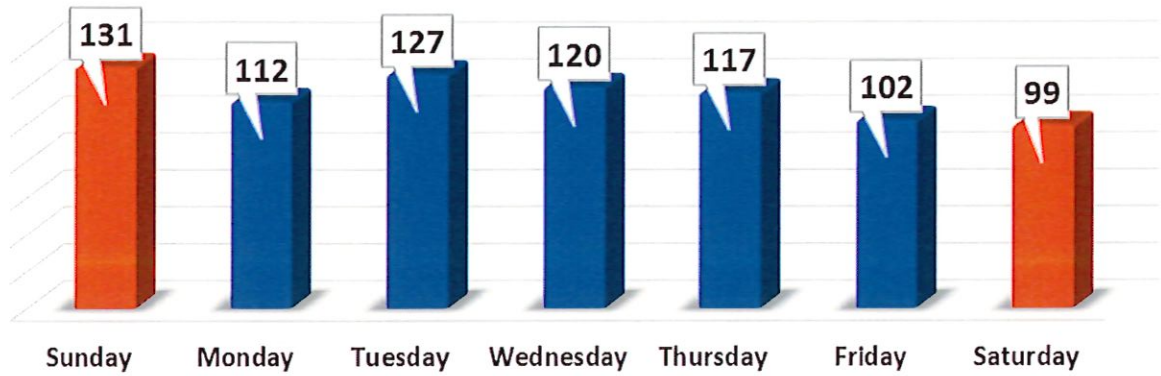

### Call Volume By Hour

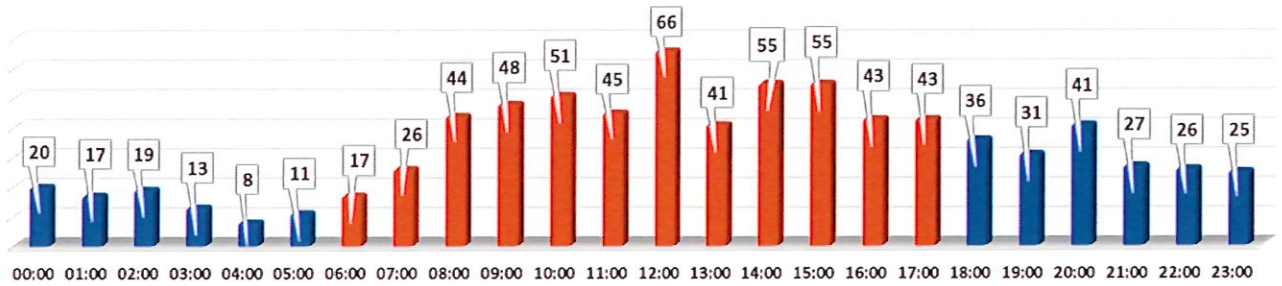

### Interfacility Transports & Special Operations

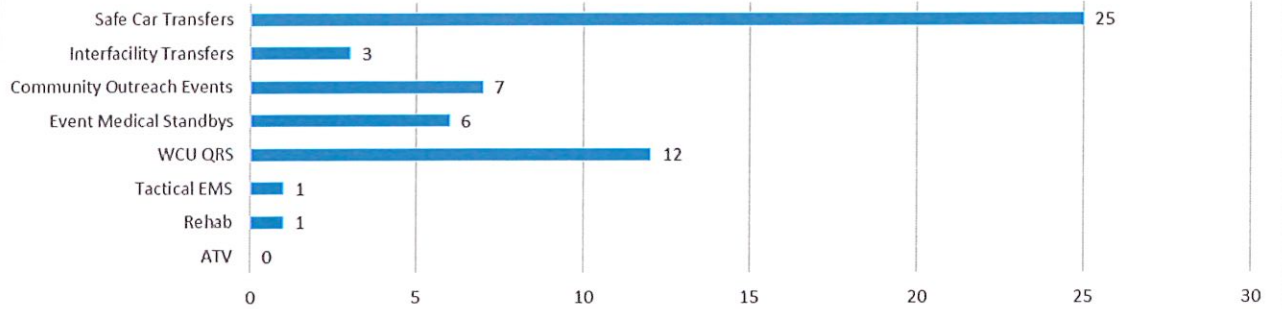

## HOSPITAL DESTINATION INFORMATION

Receiving Hospital	Total	%
Chester County Hospital	420	52.0%
Not Transported	229	28.3%
Paoli Hospital	137	17.0%
Paoli Hospital - Trauma	8	1.0%
Children's Hospital of Phila - KoP	4	0.5%
Nemours Children's Health	4	0.5%
Haven Behavioral Hospital	1	0.1%
Christiana Hospital	1	0.1%
Children's Hospital of Philadelphia	1	0.1%
Hospital of the University of Pennsylvania	1	0.1%
Riddle Hospital	1	0.1%
ChristianaCare - West Grove	1	0.1%
	<b>808</b>	
	<b>Transported: 579</b>	<b>71.7%</b>
	<b>Not Transported: 229</b>	<b>28.3%</b>
	<b>808</b>	

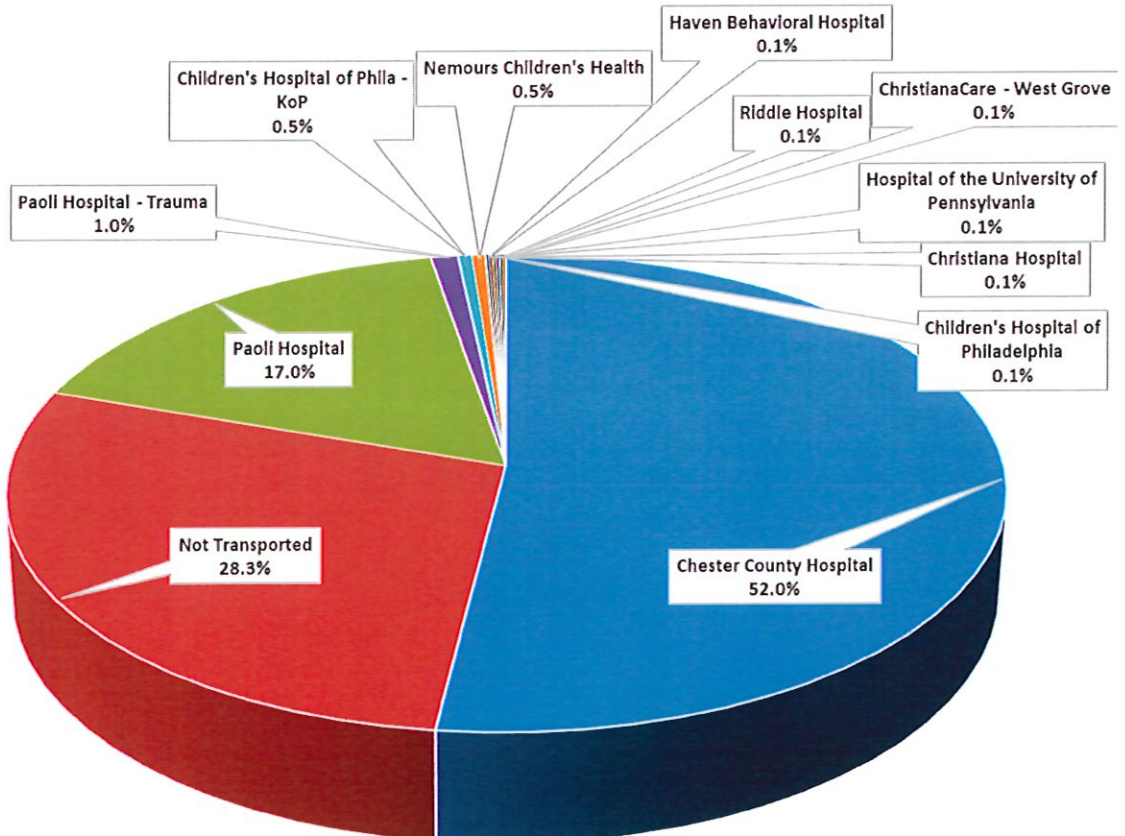

## **MISCELLANEOUS INFORMATION**

### **West Chester University Calls**

	Total	%
Total WCU Calls	28	3.5%
WCU Calls in West Chester	26	3.2%
WCU Calls in West Goshen	2	0.2%
WCU Calls in East Bradford	0	0.0%

### **Average Times**

Dispatch To Enroute	1:11
Enroute To On Scene	6:33
On Scene Time	19:36
Transport Time	12:25
ER Wait Time	13:59
Dispatch To Available	62:51

### **Alcohol / Drug Suspicion**

	Total	%
Patient Reported Alcohol Use	46	5.7%
Patient Reported Drug Use	8	1.0%
Alcohol / Drug Suspicion	12	1.5%
<b>Total:</b>	<b>66</b>	<b>8.2%</b>

### **Calls Covering Other Agencies**

Minquas Fire Co.	22
Uwchlan Ambulance	18
Goshen Fire Co.	15
East Whiteland Fire Co.	4
Concordville Fire Co.	4
Longwood Fire Co.	2
Malvern Fire Co.	1
<b>[REDACTED]</b>	<b>66</b>

### **GFAC Calls Upgraded/Downgraded**

Upgraded to ALS	40	5.0%
Upgraded to IALS	17	2.1%
Downgraded to IALS	22	2.7%
Downgraded to BLS	79	9.8%

### **Responses By Station**

Main Station (Station 55)	410
East Goshen (Station 155)	37
East Bradford (Station 255)	139
West Chester University (Station 355)	17
West Whiteland North (Station 455)	145
West Whiteland South (Station 555)	74

## ***MEDICAL CATEGORIES***

### **Call Types**

ALS Respiratory Difficulty	110	13.6%
BLS Fall	104	12.9%
BLS Sick Person	85	10.5%
ALS Heart Problems	77	9.5%
BLS Injured Person	32	4.0%
ALS Stroke	30	3.7%
BLS Mental Health Emergency	26	3.2%
BLS Accident	25	3.1%
ALS Fall	24	3.0%
ALS Unconscious Person	22	2.7%
ALS Hypotension	20	2.5%
ALS Hemorrhage	19	2.4%
ALS Unresponsive Person	17	2.1%
BLS Overdose	16	2.0%
Medical Alarm	16	2.0%
ALS Seizure	13	1.6%
ALS Syncope	13	1.6%
ALS Cardiac/Respiratory Arrest	13	1.6%
BLS Abdominal Pain	12	1.5%
ALS Overdose	12	1.5%
ALS Allergic Reaction	11	1.4%
BLS Unknown Nature	9	1.1%
ALS Accident	8	1.0%
ALS Injured Person	8	1.0%
ALS Diabetic Emergency	8	1.0%
BLS Back Pain	8	1.0%
BLS Syncope	8	1.0%
Accident with Entrapment	7	0.9%
Accident Involving a Pedestrian	6	0.7%
BLS Allergic Reaction	6	0.7%
BLS Dead on Arrival	5	0.6%
BLS Assault with Injuries	5	0.6%
BLS Seizure	4	0.5%
BLS Hemorrhage	4	0.5%
ALS Assault With Injuries	3	0.4%
CO Incident	2	0.2%
ALS Maternity	2	0.2%
House Fire	2	0.2%
Hazardous Materials Incident	2	0.2%
ALS Choking	2	0.2%
Other Rescue	2	0.2%
Building Fire	2	0.2%
Accident with Fire	2	0.2%
ALS Shooting	1	0.1%
Investigation Inside	1	0.1%
Gas Leak Inside	1	0.1%
BLS Maternity	1	0.1%
Accident Involving a Structure	1	0.1%
Appliance Fire	1	0.1%

# Memo

---

To: Board of Supervisors  
From: Kelly Brophy  
Re: April YTD Financial Report  
Date: May 28, 2026

---

The Township remains in a strong financial position through April 2026. We collected \$5,332,235 and spent \$3,843,148. This means we have received \$1.49 million more than we have spent so far this year. As of April 30th, the general fund balance is \$7,883,743.

## 2026 Budget Highlights:

Overall, we are about \$518 thousand ahead of where we expected to be at this point in the year.

We received \$341,211 more than we originally anticipated. This is largely due to higher collections from property, transfer, and earned income taxes. We also saw more activity than expected in building and reoccupancy permit fees.

Overall spending is \$177,262 lower than planned. This is due to lower costs for police services, less spending on engineering work, and lower-than-expected wages in the finance, sewer, and stormwater departments.

## Other funds:

- The **State Liquid Fuels Fund** had \$523,238 in revenues and \$0 in expenses. The fund balance is \$524,494.
- The **Capital Reserve Fund** had \$269,289 in revenues and \$578,975 in expenses. The fund balance is \$4,890,610.
- The **Transportation Fund** had \$6,687 in revenues and \$0 in expenses. The fund balance is \$543,550.
- The **Sewer Operating Fund** had \$1,807,324 in revenues and \$936,272 in expenses. The fund balance is \$2,719,876.
- The **Refuse Fund** had \$447,419 in revenues and \$521,236 in expenses. The fund balance is \$209,277.
- The **Bond Fund** had \$7,067 in revenues and \$12,480 in expenses. The fund balance is \$596,064.
- The **Sewer Capital Reserve Fund** had \$24,551 in revenues and \$35,669 in expenses. The fund balance is \$2,233,587.
- The **Operating Reserve Fund** had \$22,497 in revenues and \$0 in expenses. The fund balance is \$1,828,660.
- The **Infrastructure Sustainability Fund** had \$11,405 in revenues and \$2,838 in expenses. The fund balance is \$1,453,768.



**EAST GOSHEN TOWNSHIP**  
 Variance Detail Report  
 Year to Date As of April 30, 2026  
**GENERAL FUND**

REVENUES	YTD Pr Yr	YTD Budget	YTD Actual	\$ Favorable/ (Unfavorable)	Comments on YTD Budget Variance
LOCAL ENABLING TAXES*	4,255,041	4,219,607	4,629,364	409,757	Real Estate Property tax, Transfer tax & EIT tax higher than expected
LICENSE & PERMITS	99,571	91,875	91,999	124	
FINES	58,903	15,690	9,134	(6,556)	False Fire Alarms less than expected
INTEREST EARNINGS	57,325	61,000	43,076	(17,924)	Interest less than expected
RENTS	34,954	36,791	36,545	(246)	
STATE SHARED REVENUE & ENTITLEMENT	4,813	5,150	4,813	(338)	
GENERAL GOVERNMENT	22,463	13,723	1,379	(12,345)	Engineering Fees less than expected
PUBLIC SAFETY	105,661	109,299	136,397	27,098	Building & Reoccupancy Permit fee collections are higher than expected
HIGHWAY & STREETS	6,025	300	4,596	4,296	
CULTURE & RECREATION	241,258	250,923	238,065	(12,858)	Community day food trucks, tennis
MISCELLANEOUS REVENUE	59,509	51,667	21,138	(30,528)	Insurance dividends less than expected
INTERFUND OPERATING TRANSFERS	244,379	135,000	115,731	(19,270)	Sewer transfer less than expected
<b>TOTAL REVENUES</b>	<b>5,189,901</b>	<b>4,991,025</b>	<b>5,332,235</b>	<b>341,211</b>	
<b>EXPENSES</b>					
GENERAL GOVERNMENT	407,338	410,211	289,053	121,158	Engineering recharges & finance wages less than expected
TAX COLLECTION	35,406	38,858	30,105	8,754	
GENERAL GOVERNMENT BLDG & PLANT	100,017	127,717	166,298	(38,581)	PW Building Maint & Repairs hirer than expected
PUBLIC SAFETY	1,642,914	1,736,642	1,690,515	46,127	Police expenses less than expected
PLANNING & ZONING	155,826	158,404	155,256	3,148	
RECYCLING	0	0	0	0	
PUBLIC WORKS - SANITATION	158,739	168,771	87,229	81,542	Sewer & stormwater wages less than expected
PUBLIC WORKS - HWYS ROADS & STREETS	706,374	686,290	779,152	(92,862)	Snow wages, snow supplies & road wages hirer than expected
PARTICIPANT RECREATION	106,479	106,278	97,189	9,089	Tennis & pickleball court
PARKS	79,246	67,228	103,062	(35,834)	Salary for Park Maint and Park Maint & Repairs hirer than expected
CONSERVATION & DEVELOPMENT	150	0	679	(679)	
HISTORICAL	300	0	300	(300)	
DEBT SERVICE	67,500	67,500	64,200	3,300	
PENSION FUND CONTRIBUTION	29,323	86,245	85,176	1,069	
INSURANCE PREMIUMS	248,203	261,932	216,619	45,314	
EMPLOYEE BENEFITS	87,661	104,333	78,316	26,017	
INTERFUND TRANSFERS	0	0	0	0	
<b>TOTAL EXPENSES</b>	<b>3,825,476</b>	<b>4,020,410</b>	<b>3,843,148</b>	<b>177,262</b>	
<b>NET RESULTS FROM OPERATIONS</b>	<b>1,364,425</b>	<b>970,615</b>	<b>1,489,087</b>	<b>518,472</b>	

**MONTH END FUND BALANCE REPORT  
ALL FUNDS APRIL 2026**

\* NOTE: GENERAL FUND INCLUDES PASS-THROUGH ACCOUNTS

	01 GENERAL FUND*	02 LIQUID FUELS STATE FUND	03 CAP RESV FUND	04 TRANSPORT. FUND	05 SEWER OP. FUND	06 REFUSE FUND	09 SEWER CAP RESV FUND	10 OPERATING RESERVE	12 INFRASTRUCTURE SUSTAIN	TOWNSHIP FUNDS	07 MUNICIPAL AUTHORITY	08 BOND FUND
1/1/26 BEGINNING BALANCE	\$6,475,925	\$1,256	\$5,200,297	\$536,864	\$1,848,825	\$283,094	\$2,244,705	\$1,806,163	\$1,445,201	\$19,842,330	\$28,367	\$601,476
<b>RECEIPTS</b>												
310 TAXES	4,754,884	0	0	0	0	0	0	0	0	4,754,884	0	0
320 LICENSES & PERMITS	91,999	0	0	0	0	0	0	0	0	91,999	0	0
330 FINES & FORFEITS	9,134	0	0	0	0	0	0	0	0	9,134	0	0
340 INTERESTS & RENTS	79,621	3,223	269,289	6,687	21,194	2,266	24,551	22,497	8,435	437,761	61	7,067
350 INTERGOVERNMENTAL	4,813	520,015	0	0	0	0	0	0	2,970	527,797	0	0
360 CHARGES FOR SERVICES	377,936	0	0	0	1,786,130	445,153	0	0	0	2,609,219	16,500	0
380 MISCELLANEOUS REVENUES	1,053,104	0	0	0	0	0	0	0	0	1,053,104	0	0
390 OTHER FINANCING SOURCES	115,731	0	0	0	0	0	0	0	0	115,731	109,247	0
<b>TOTAL RECEIPTS</b>	<b>\$6,487,221</b>	<b>\$523,238</b>	<b>\$269,289</b>	<b>\$6,687</b>	<b>\$1,807,324</b>	<b>\$447,419</b>	<b>\$24,551</b>	<b>\$22,497</b>	<b>\$11,405</b>	<b>\$9,599,629</b>	<b>\$125,808</b>	<b>\$7,067</b>
<b>EXPENDITURES</b>												
400 GENERAL GOVERNMENT	548,234	0	55,077	0	0	0	0	0	0	603,311	0	0
410 PUBLIC SAFETY	2,790,577	0	0	0	0	0	0	0	0	2,790,577	0	0
420 HEALTH & WELFARE	0	0	0	0	518,304	0	0	0	0	518,304	73,578	0
426 SANITATION & REFUSE	44,417	0	0	0	256,026	521,236	0	0	0	821,679	35,669	0
430 HIGHWAYS,ROADS & STREETS	821,946	0	522,040	0	0	0	0	0	0	1,343,986	0	0
450 CULTURE-RECREATION	200,250	0	1,399	0	0	0	0	0	2,838	204,487	0	12,480
460 CONSERVATION & DEVELOPMENT	979	0	0	0	0	0	0	0	0	979	0	0
470 DEBT SERVICE	64,200	0	0	0	88,364	0	0	0	0	152,564	0	0
480 MISCELLANEOUS EXPENDITURES	458,595	0	0	0	0	0	0	0	0	458,595	0	0
490 OTHER FINANCING USES	0	0	460	0	73,578	0	35,669	0	0	109,707	0	0
<b>TOTAL EXPENDITURES</b>	<b>\$4,929,199</b>	<b>\$0</b>	<b>\$578,975</b>	<b>\$0</b>	<b>\$936,272</b>	<b>\$521,236</b>	<b>\$35,669</b>	<b>\$0</b>	<b>\$2,838</b>	<b>\$7,004,190</b>	<b>\$109,247</b>	<b>\$12,480</b>
SURPLUS/(DEFICIT)	\$1,558,022	\$523,238	(\$309,687)	\$6,687	\$871,051	(\$73,817)	(\$11,118)	\$22,497	\$8,567	\$2,595,439	\$16,561	(\$5,413)
4/30/26 ENDING BALANCE	\$8,018,164	\$524,494	\$4,890,610	\$543,550	\$2,719,876	\$209,277	\$2,233,587	\$1,828,660	\$1,453,768	\$22,421,985	\$44,929	\$596,064
CLEARING ACCOUNT ADJUSTMENTS	(\$134,421)									(\$134,421)		
<b>ADJUSTED CASH BALANCE</b>	<b>\$7,883,743</b>	<b>\$524,494</b>	<b>\$4,890,610</b>	<b>\$543,550</b>	<b>\$2,719,876</b>	<b>\$209,277</b>	<b>\$2,233,587</b>	<b>\$1,828,660</b>	<b>\$1,453,768</b>	<b>\$22,303,348</b>	<b>\$44,929</b>	<b>\$596,064</b>

---

---

**EAST GOSHEN TOWNSHIP  
MEMORANDUM**

---

---

**TO:** BOARD OF SUPERVISORS  
**FROM:** DANA GIEDER  
**SUBJECT:** PROPOSED PAYMENTS OF BILLS  
**DATE:** MAY 28, 2026

---

Attached please find the Treasurer's Report for the weeks of April 30, 2026- May 28, 2026.

Real Estate tax collections, EIT & LST collections, transfer tax revenue, interest income, rent, permits, alarm fees, P&R registrations, pavilion rentals, and interest income from the maturity of term investments drove General Fund revenue during this period.

General Fund expenses include the monthly WEGO contribution, the 2026 WEGO building capital contribution, progress and final billing for auditing expenses, vehicle maintenance/repairs, highway materials, building maintenance/repairs, tree removal, legal and engineering costs, P&R programs/events/maintenance, insurance payments, and routine operational expenses.

Expenditures from the Capital Reserve Fund include \$7K for a replacement HVAC ground water pump at the township building, \$9K to replace the MIG welder and the machine to repair A/C in equipment, and \$5K for engineering costs.

Expenditures from the Infrastructure Sustainability Fund are for March and April water sampling costs.

**Recommended motion:** Mr. Chairman, I move that we accept the receipts and approve the expenditures as presented in the Expenditure Register and as summarized in the Treasurer's Report.

\*\*\*\*\*NOTE: Board of Supervisor, Larry cannot vote on these proposed payments of bills as he has a refund check included in this batch.

TREASURER'S REPORT  
RECEIPTS AND BILLS

April 30, 2026- May 28, 2026

<b>GENERAL FUND</b>			
Real Estate Tax	\$268,347.09	Accounts Payable	\$784,774.54
Earned Income Tax	\$1,345,274.16	Electronic Pmts:	
Local Service Tax	\$73,945.80	Debt Service	\$0.00
Transfer Tax	\$57,157.52	Payroll	\$384,612.53
General Fund Interest Earned	\$54,058.26		
Total Other Revenue	\$415,066.88		
Year End Transfer 2026	\$0.00		
<b>Total General Fund Receipts:</b>	<b>\$2,213,849.71</b>	<b>Total Expenditures:</b>	<b>\$1,169,387.07</b>
<b>STATE LIQUID FUELS FUND</b>			
Receipts	\$0.00	Accounts Payable	\$0.00
Interest Earned	\$1,609.08		
<b>Total State Liquid Fuels Receipts:</b>	<b>\$1,609.08</b>	<b>Total Expenditures:</b>	<b>\$0.00</b>
<b>CAPITAL RESERVE FUND</b>			
Receipts	\$0.00	Accounts Payable	\$26,763.60
Interest Earned	\$51,755.09		
Year End Transfer 2026	\$0.00		
<b>Total Capital Reserve Fund Receipts:</b>	<b>\$51,755.09</b>	<b>Total Expenditures:</b>	<b>\$26,763.60</b>
<b>TRANSPORTATION FUND</b>			
Receipts	\$0.00	Accounts Payable	\$0.00
Interest Earned	\$1,667.47		
<b>Total Transportation Fund Receipts:</b>	<b>\$1,667.47</b>	<b>Total Expenditures:</b>	<b>\$0.00</b>
<b>SEWER OPERATING FUND</b>			
Receipts	\$591,859.70	Accounts Payable	\$115,874.66
Interest Earned	\$6,094.57	Electronic Pmts:	
Year End Transfer 2026	\$0.00	Debt Service	\$15,367.37
<b>Total Sewer Operating Fund Receipts:</b>	<b>\$597,954.27</b>	<b>Total Expenditures:</b>	<b>\$131,242.03</b>
<b>REFUSE FUND</b>			
Receipts	\$174,431.81	Accounts Payable	\$115,272.55
Interest Earned	\$394.50		
<b>Total Refuse Fund Receipts:</b>	<b>\$174,826.31</b>	<b>Total Expenditures:</b>	<b>\$115,272.55</b>
<b>BOND FUND</b>			
Receipts	\$0.00	Accounts Payable	\$0.00
Interest Earned	\$1,741.75		
<b>Total Bond Fund Receipts:</b>	<b>\$1,741.75</b>	<b>Total Expenditures:</b>	<b>\$0.00</b>
<b>SEWER CAPITAL RESERVE FUND</b>			
Receipts	\$0.00	Accounts Payable	\$0.00
Interest Earned	\$6,087.08		
Year End Transfer 2026	\$0.00		
<b>Total Sewer Capital Reserve Fund Receipts:</b>	<b>\$6,087.08</b>	<b>Total Expenditures:</b>	<b>\$0.00</b>
<b>OPERATING RESERVE FUND</b>			
Receipts	\$0.00	Accounts Payable	\$0.00
Interest Earned	\$5,610.10		
<b>Total Operating Reserve Fund Receipts:</b>	<b>\$5,610.10</b>	<b>Total Expenditures:</b>	<b>\$0.00</b>
<b>INFRASTRUCTURE SUSTAINABILITY FUND</b>			
Receipts	\$0.00	Accounts Payable	\$876.09
Interest Earned	\$2,103.45		
<b>Total Infrastructure Sustainability Fund Receipts:</b>	<b>\$2,103.45</b>	<b>Total Expenditures:</b>	<b>\$876.09</b>
<b>ARPA - COVID RELIEF FUND</b>			
Receipts	\$0.00	Accounts Payable	\$0.00
Interest Earned	\$0.00		
<b>Total ARPA - COVID Relief Fund Receipts:</b>	<b>\$0.00</b>	<b>Total Expenditures:</b>	<b>\$0.00</b>

**East Goshen Township**  
Purchase Order Listing By Expenditure Account

Ranges	Item Status	Purchase Types	Misc
Range: 5014000000 to 6199999999 Rcvd Batch Id Range: First to Last Paid Date Range: 04/30/26 to 05/28/26	Open: N Void: N Paid: Y Held: N Aprv: N Rcvd: N	Bid: Y State: Y Other: Y Exempt: Y	P.O. Type: All Format: Detail without Line Item Notes Include Non-Budgeted: Y Prior Year Only: N * Means Prior Year Line: Vendors: All DEPT Page Break: No Subtotal DEPT: No

Expenditure Account		Description											
P.O. Id	Item	Vendor Id	Vendor Name	Item Description	Amount	Stat/Chk	First Enc Date	Rcvd Date	Chk/Void Date	Invoice	PO Type		
01-401-2100		MATERIALS & SUPPLIES											
26-00988	1	WBMA005	W.B.MASON CO.,INC.	COFFEE K-CUPS AND TOILET PAPER	\$234.14	P 28343	05/06/26	05/06/26	05/07/26	261429248			
26-01069	1	STAPL010	STAPLES, INC	NAME BADGE	\$19.79	P 28359	05/13/26	05/13/26	05/13/26	6055828294			
26-01093	1	STAPL010	STAPLES, INC	HP OFFICEJET PRINTER & INK	\$214.94	P 28359	05/13/26	05/13/26	05/13/26				
26-01128	1	ODPBU005	ODP BUSINESS SOLUTIONS LLC	LARGE BINDER CLIPS	\$33.39	P 28381	05/19/26	05/20/26	05/20/26	467291860001			
26-01129	1	ODPBU005	ODP BUSINESS SOLUTIONS LLC	CLASP ENVELOPES, MED BINDER CL	\$25.39	P 28381	05/19/26	05/20/26	05/20/26	467290979001			
					<b>\$527.65</b>								
01-401-3000		GENERAL EXPENSE											
26-01024	1	PENNS035	PENNSYLVANIA STATE POLICE	BACKGROUND CHECK- E. BELAIR	\$22.00	P 28336	05/07/26	05/07/26	05/07/26	R34845066			
26-01024	2	PENNS035	PENNSYLVANIA STATE POLICE	BACKGROUND CHECK- W. HEISTER	\$22.00	P 28336	05/07/26	05/07/26	05/07/26	R34845067			
26-01024	3	PENNS035	PENNSYLVANIA STATE POLICE	BACKGROUND CHECK- M. FUENTES	\$22.00	P 28336	05/07/26	05/07/26	05/07/26	R34845068			
26-01024	4	PENNS035	PENNSYLVANIA STATE POLICE	BACKGROUND CHECK- J. DAMASCO	\$22.00	P 28336	05/07/26	05/07/26	05/07/26	R34845286			
26-01024	5	PENNS035	PENNSYLVANIA STATE POLICE	BACKGROUND CHECK- E. LANTRIP	\$22.00	P 28336	05/07/26	05/07/26	05/07/26	R34845287			
26-01024	6	PENNS035	PENNSYLVANIA STATE POLICE	BACKGROUND CHECK- M. WINTERS	\$22.00	P 28336	05/07/26	05/07/26	05/07/26	R34845288			
26-01024	7	PENNS035	PENNSYLVANIA STATE POLICE	BACKGROUND CHECK- L.HARCOURT	\$22.00	P 28336	05/07/26	05/07/26	05/07/26	R34980826			
26-01089	1	PAMA005	PAMA- PA ASSOC OF MUNICIPAL AD	PAMA MEMBERSHIP 26-27 A.NOWAK	\$150.00	P 28356	05/13/26	05/13/26	05/13/26	INV-193571-W2R9			
					<b>\$304.00</b>								
01-401-3070		PSATS EXPENSE											
26-01086	1	MASSA005	MASSARRO, LARRY	REIMBURSE FOR PSATS EXPENSES	\$35.71	P 28354	05/13/26	05/13/26	05/13/26	050426			
01-401-3120		CONSULTING SERVICES											
26-01155	1	HELPN005	HELP-NOW,LLC	MAY 2026	\$3,108.00	P 28370	05/20/26	05/20/26	05/20/26	31487			
26-01156	1	HELPN005	HELP-NOW,LLC	REMOTE/VIRT CONSULTING/SERVICE	\$483.35	P 28370	05/20/26	05/20/26	05/20/26	31396			
					<b>\$3,591.35</b>								

East Goshen Township  
Purchase Order Listing By Expenditure Account

Expenditure Account		Description											
P.O. Id	Item	Vendor Id	Vendor Name	Item Description	Amount	Stat/Chk	First Enc Date	Rcvd Date	Chk/Void Date	Invoice	PO Type		
01-401-3210			COMMUNICATION EXPENSE										
26-00972	1	VERIZ045	VERIZON 357-044-996-0001-93	4/21-5/20/26 FIOS TWP BLDG #2	\$179.00	P 652	04/30/26	04/30/26	04/30/26	042026			
26-00974	1	VERIZ040	VERIZON - 542413545-00001	3/22-4/21/26 MULT.TWP CELL PHO	\$480.32	P 651	04/30/26	04/30/26	04/30/26	6141656560			
26-01018	1	GRAFF005	GRAFFEN BUSINESS SYSTEMS, INC	VOIP- FAX ATA (ONE TIME FEE)	\$100.00	P 28323	05/07/26	05/07/26	05/07/26	87917			
26-01019	1	GRAFF005	GRAFFEN BUSINESS SYSTEMS, INC	APRIL 2026 VOIP PHONE SERVICE	\$764.41	P 28323	05/07/26	05/07/26	05/07/26	INV-001082			
26-01020	1	GRAFF005	GRAFFEN BUSINESS SYSTEMS, INC	MAY 2026 VOIP PHONE SERVICE	\$764.41	P 28323	05/07/26	05/07/26	05/07/26	INV-001088			
26-01049	1	COMCA005	COMCAST 8499-10-109-0028306	0028306 MAY 2026	\$303.34	P 653	05/12/26	05/12/26	05/12/26	042226			
26-01055	1	TWPFI005	VERIZON - TWP.FIOS 0001-74	4/28/26- 5/27/26 TWP FIOS 1	\$109.99	P 656	05/12/26	05/12/26	05/12/26	042726			
26-01084	1	FIRST015	FIRSTNET - #287290606505	APRIL 2026	\$1,765.73	P 28349	05/13/26	05/13/26	05/13/26	05082026			
26-01177	1	COMCA010	COMCAST 8499-10-109-0107472	0107472 5/17-6/16/26 PW TV	\$31.58	P 658	05/26/26	05/26/26	05/26/26	051026			
					<b>\$4,498.78</b>								
01-401-3400			ADVERTISING - PRINTING										
26-00983	1	21STC005	21ST CENT.MEDIA NEWS #884433	NOTICE- ZONING HEARING 051226	\$193.80	P 28315	05/06/26	05/06/26	05/07/26	2807212			
01-401-3410			ABC APPRECIATION EVENT										
26-01021	1	SEROC005	SEROCK, JOHN CATERING	CATERING DEPOSIT FOR ABC APPRE	\$500.00	P 28339	05/07/26	05/07/26	05/07/26	043026			
01-401-3840			RENTAL OF EQUIP. -OFFICE										
26-01038	1	GREAT010	GREAT AMERICA FINANCIAL SERVIC	MAY 2026 LANIER & RICOH	\$218.00	P 657	05/07/26	05/07/26	05/07/26	41843145			
01-402-3110			AUDITING EXPENSE										
26-00989	1	MAILL005	MAILLIE LLP	PROGRESS BILLING EGT FINANCIAL	\$15,000.00	P 28334	05/06/26	05/06/26	05/07/26	127794			
26-01163	1	MAILL005	MAILLIE LLP	FINAL BILLING EGT FINANCIAL	\$10,250.00	P 28378	05/20/26	05/20/26	05/20/26	129760			
					<b>\$25,250.00</b>								
01-404-3140			LEGAL - ADMIN										
26-01082	1	PC000005	LAMB MCERLANE PC	LEGAL SERV APR 2026 GENERAL	\$3,705.80	P 28357	05/13/26	05/13/26	05/13/26	400640			
01-408-3130			ENGINEERING SERVICES										
26-01144	1	PENNO005	PENNONI ASSOCIATES INC.	SERV THRU 032926 TRBL ELLIS LL	\$166.00	P 28383	05/19/26	05/19/26	05/20/26	1322751			
26-01149	1	PENNO005	PENNONI ASSOCIATES INC.	SERV THRU 032926 ELLIS LANE BR	\$610.50	P 28383	05/19/26	05/19/26	05/20/26	1322743			
26-01151	1	PENNO005	PENNONI ASSOCIATES INC.	SERV THRU 032926 GEN CONSULT	\$444.50	P 28383	05/19/26	05/19/26	05/20/26	1322742			

**East Goshen Township**  
Purchase Order Listing By Expenditure Account

Expenditure Account		Description													
P.O. Id	Item	Vendor Id	Vendor Name	Item Description	Amount	Stat/Chk	First Enc Date	Rcvd Date	Chk/Void Date	Invoice	PO Type				
					<b>\$1,221.00</b>										
01-408-3131			ENGINEER.& MISC.RECHARGES												
26-01145	1	PENNO005	PENNONI ASSOCIATES INC.	SERV THRU 032926 48 SHERMAN DR	\$290.50	P 28383	05/19/26	05/20/26	05/20/26	1322752					
26-01146	1	PENNO005	PENNONI ASSOCIATES INC.	SERV THRU 032926 301 RESERVOIR	\$792.50	P 28383	05/19/26	05/19/26	05/20/26	1322748					
26-01147	1	PENNO005	PENNONI ASSOCIATES INC.	SERV THRU 032926 WCU FOUNDATIO	\$173.00	P 28383	05/19/26	05/19/26	05/20/26	1322749					
26-01148	1	PENNO005	PENNONI ASSOCIATES INC.	SERV THRU 032926 THOMAS, 1344	\$1,351.50	P 28383	05/19/26	05/19/26	05/20/26	1322750					
26-01150	1	PENNO005	PENNONI ASSOCIATES INC.	SERV THRU 032926 MILLSTONE MEA	\$201.50	P 28383	05/19/26	05/19/26	05/20/26	1322747					
					<b>\$2,809.00</b>										
01-409-3600			TWP. BLDG. - FUEL, LIGHT, WATER												
26-00978	1	EASTG035	EAST GOSHEN TWP - SEWER	QTR 2 2026 SEWER TWP	\$390.61	P 651	05/01/26	05/01/26	05/01/26	041526- TWP					
26-00981	1	PECO1010	PECO - 1138974000	1138974000 3/30-4/29 TWP BLDG	\$2,947.97	P 655	05/01/26	05/01/26	05/01/26	043026					
26-00986	1	AQUAP010	AQUA PA 01	309801 0309801 3/19- 4/21 BS	\$24.06	P 28316	05/06/26	05/06/26	05/07/26	042326 BS					
26-01035	1	PECO0045	PECO - 5540052222	5540052222 4/2- 5/1/26 BOOT	\$87.29	P 660	05/07/26	05/07/26	05/07/26	050426					
26-01041	1	PECO7005	PECO - 7898928000	7898928000 3/30-4/29 0 BOOT	\$70.97	P 662	05/07/26	05/07/26	05/07/26	043026					
26-01105	1	PECO5020	PECO - 5184333000	5184333000 3/30-4/29BOOTRD,HIS	\$70.53	P 669	05/18/26	05/18/26	05/18/26	043026					
26-01106	1	PECO3005	PECO - 3598108000	3598108000 3/30-4/29 BLACKSMIT	\$107.43	P 667	05/18/26	05/18/26	05/18/26	043026					
					<b>\$3,698.86</b>										
01-409-3605			PW BLDG - FUEL,LIGHT,SEWER & WATER												
26-00979	1	EASTG035	EAST GOSHEN TWP - SEWER	QTR 2 2026 SEWER PW	\$948.61	P 652	05/01/26	05/01/26	05/01/26	041526- PW					
26-01101	2	PECO0015	PECO - 8512154000	8512154000 3/24/26- 4/23/26	\$1,050.80	P 665	05/18/26	05/18/26	05/18/26	051126					
					<b>\$1,999.41</b>										
01-409-3740			TWP. BLDG. - MAINT & REPAIRS												
26-01010	1	LOCKS005	GREAT VALLEY LOCKSHOP	ADJUST BEEZEWAY CLOSER- FRONT	\$144.00	P 28333	05/07/26	05/07/26	05/07/26	20253638					
26-01030	1	CINTA005	CINTAS CORPORATION	UNIFORMS & MATS SETTLEMENT	\$757.97	P 28319	05/07/26	05/07/26	05/07/26	050526					
26-01037	8	LOWES005	LOWES BUSINESS ACCOUNT/GECF	VARIOUS PURCHASES- SEE NOTES	\$75.98	P 658	05/07/26	05/07/26	05/07/26	041726					
26-01124	1	SPECI010	SPECIALIZED ELEVATOR CORP	ELEVATOR MAINTENANCE MAY 2026	\$72.14	P 28385	05/19/26	05/19/26	05/20/26	476747					
26-01125	1	CLEAN015	CLEAN RIGHT BUILDING SERVICES	JANITORIAL SERV APRIL 2026	\$1,375.00	P 28361	05/19/26	05/19/26	05/20/26	CL12267					
26-01127	8	JASPE005	JASPER PEST CONTOL, LLC	PEST CONTROL MARCH 2026	\$75.00	P 28374	05/19/26	05/19/26	05/20/26	2672					
26-01132	1	WBMAS005	W.B.MASON CO.,INC.	TRASH BAGS, PAPER TOWELS, TOIL	\$196.50	P 28389	05/19/26	05/19/26	05/20/26	261691398					
26-01136	1	LOCKS005	GREAT VALLEY LOCKSHOP	FIX FRONT TWP BLDG DOORS	\$150.00	P 28377	05/19/26	05/19/26	05/20/26	0020261747					

East Goshen Township  
Purchase Order Listing By Expenditure Account

Expenditure Account		Description											
P.O. Id	Item	Vendor Id	Vendor Name	Item Description	Amount	Stat/Chk	First Enc Date	Rcvd Date	Chk/Void Date	Invoice	PO Type		
					<b>\$2,846.59</b>								
01-409-3745			PW BUILDING - MAINT REPAIRS										
26-01127	9	JASPE005	JASPER PEST CONTOL, LLC	PEST CONTROL MARCH 2026	\$75.00	P 28374	05/19/26	05/19/26	05/20/26	2672			
26-01127	10	JASPE005	JASPER PEST CONTOL, LLC	PEST CONTROL MARCH 2026	\$25.00	P 28374	05/19/26	05/19/26	05/20/26	2672			
26-01137	1	VAZQU005	VAZQUEZ, JUAN MARTINEZ	PAINT LOCKER RM, DINING RM,HAL	\$690.00	P 28388	05/19/26	05/19/26	05/20/26	050926			
					<b>\$790.00</b>								
01-409-3840			DISTRICT COURT EXPENSES										
26-00970	1	VERIZ025	VERIZON-1420	4/16-5/15/26 DC ALARM SYSTEM	\$98.64	P 650	04/30/26	04/30/26	04/30/26	041526			
26-01101	1	PECO0015	PECO - 8512154000	8512154000 3/24/26- 4/23/26	\$802.26	P 665	05/18/26	05/18/26	05/18/26	051126			
26-01125	2	CLEAN015	CLEAN RIGHT BUILDING SERVICES	JANITORIAL SERV APRIL 2026	\$808.00	P 28361	05/19/26	05/19/26	05/20/26	CL12267			
26-01127	7	JASPE005	JASPER PEST CONTOL, LLC	PEST CONTROL MARCH 2026	\$75.00	P 28374	05/19/26	05/19/26	05/20/26	2672			
					<b>\$1,783.90</b>								
01-410-5300			POLICE GEN.EXPENSE										
26-01080	1	WESTT010	WESTTOWN-EAST GOSHEN POLICE	JUNE 2026 CONTRIBUTION	\$403,203.36	P 28360	05/13/26	05/13/26	05/13/26	060126			
01-410-5330			CAPITAL CONTRIBUTION - POLICE BLDG										
26-01126	1	WESTT010	WESTTOWN-EAST GOSHEN POLICE	2026 WEGO BLDG CAPITAL CONTRIB	\$22,650.00	P 28391	05/19/26	05/19/26	05/20/26	051126			
01-410-5400			S.P.C.A. CONTRACT										
26-01123	1	SPCA0005	BRANDYWINE VALLEY SPCA	STRAY/PICKUP ACTIV. APRIL 2026	\$427.22	P 28384	05/19/26	05/19/26	05/20/26	APR26-07			
01-411-3630			HYDRANT & WATER SERVICE										
26-01031	1	AQUAP025	AQUA PA - HY	310033 0310033 3/31-4/30 186	\$6,015.53	P 28317	05/07/26	05/07/26	05/07/26	050126 279			
26-01032	1	AQUAP025	AQUA PA - HY	309987 0309987 3/31- 4/30 HY6	\$194.07	P 28317	05/07/26	05/07/26	05/07/26	050126 HY6			
					<b>\$6,209.60</b>								
01-411-3631			HYDRANTS - RECHARGE EXPENSE										
26-01031	2	AQUAP025	AQUA PA - HY	310033 0310033 3/31-4/30 93	\$3,008.55	P 28317	05/07/26	05/07/26	05/07/26	050126 279			
01-411-6000			VOLUNTEER FIREFIGHTER WORKERS COMP										
26-01029	1	STATE005	STATE WORKERS INSURANCE FUND	POLICY# 05918452 INSTL 5 OF 10	\$3,334.00	P 28341	05/07/26	05/07/26	05/07/26	050126			

**East Goshen Township**  
Purchase Order Listing By Expenditure Account

Expenditure Account		Description									
P.O. Id	Item	Vendor Id	Vendor Name	Item Description	Amount	Stat/Chk	First Enc Date	Rcvd Date	Chk/Void Date	Invoice	PO Type
01-413-3130			ENGINEERING SERVICES								
26-01078	1	ARROC005	ARRO CONSULTING INC.	PROF SERVICES THRU 050126	\$6,261.25	P 28344	05/13/26	05/13/26	05/13/26	0119763	
01-413-3840			RENTAL OF EQUIP. -CODES								
26-01038	2	GREAT010	GREAT AMERICA FINANCIAL SERVIC	MAY 2026 LANIER & RICOH	\$116.00	P 657	05/07/26	05/07/26	05/07/26	41843145	
01-414-3141			LEGAL - ZONING HEARING BOARD								
26-01022	1	FREES005	UNRUH TURNER BURKE FREES	LEGAL SERV 3/25-4/22/26CAMPBEL	\$382.50	P 28322	05/07/26	05/07/26	05/07/26	234420	
01-414-3143			LEGAL - SUBDIVISION & LAND DEVELOP								
26-01081	1	PC000005	LAMB MCERLANE PC	LEGAL SERV APR 2026 WCU FOUND	\$700.00	P 28357	05/13/26	05/13/26	05/13/26	400642	
01-427-4900			E-RECYCLING EVENTS								
26-01027	1	EFORC005	EFORCE COMPLIANCE	RECYCLING &E-WASTE EVENT050226	\$3,500.00	P 28321	05/07/26	05/07/26	05/07/26		
01-430-2320			VEHICLE OPERATION - FUEL								
26-00968	1	RHOAD010	RHOADS ENERGY	344.2 GALS DIESEL	\$1,369.40	P 649	04/30/26	04/30/26	04/30/26	24934119	
26-00969	1	RHOAD010	RHOADS ENERGY	153.4 GALS GASOLINE	\$521.79	P 649	04/30/26	04/30/26	04/30/26	24934319	
26-01042	1	RHOAD010	RHOADS ENERGY	504.2 GALS DIESEL	\$2,091.67	P 655	05/12/26	05/12/26	05/12/26	24968809	
26-01043	1	RHOAD010	RHOADS ENERGY	342.5 GALS GASOLINE	\$1,240.36	P 655	05/12/26	05/12/26	05/12/26		
26-01044	1	RHOAD010	RHOADS ENERGY	537.5 GALS DIESEL	\$2,313.13	P 655	05/12/26	05/12/26	05/12/26		
26-01045	1	RHOAD010	RHOADS ENERGY	320.5 GALS GASOLINE	\$1,264.85	P 655	05/12/26	05/12/26	05/12/26	24996909	
26-01172	1	RHOAD010	RHOADS ENERGY	357.4 GALS DIESEL	\$1,523.77	P 660	05/26/26	05/26/26	05/26/26	25035506	
26-01173	1	RHOAD010	RHOADS ENERGY	267.2 GALS GASOLINE	\$1,086.57	P 660	05/26/26	05/26/26	05/26/26	25035665	
					<b>\$11,411.54</b>						
01-430-2325			MAINTENANCE AND REPAIRS - FUEL TANK								
26-01162	1	HAFER005	HAFER PETROLEUM EQUIPMENT	ELECTRONIC ISSUES W/ GAS PUMPS	\$324.50	P 28368	05/20/26	05/20/26	05/20/26	27995	
01-430-2330			VEHICLE MAINT AND REPAIR								
26-00990	1	KENTA005	KENT AUTOMOTIVE	BUNA ORINGS	\$60.68	P 28332	05/06/26	05/06/26	05/07/26	9313418817	
26-00991	1	KENTA005	KENT AUTOMOTIVE	LAG SCREWS AND FLAT WASHERS	\$107.28	P 28332	05/06/26	05/06/26	05/07/26	9313417748	
26-01001	1	SAFET010	SAFETY-KLEEN SYSTEMS, INC	PARTS WASHER SOLVENT, 55 GAL	\$549.42	P 28338	05/07/26	05/07/26	05/07/26	99624939	

East Goshen Township  
Purchase Order Listing By Expenditure Account

Expenditure Account		Description											
P.O. Id	Item	Vendor Id	Vendor Name	Item Description	Amount	Stat/Chk	First Enc Date	Rcvd Date	Chk/Void Date	Invoice	PO Type		
01-430-2330			VEHICLE MAINT AND REPAIR	Account Continued									
26-01012	1	KENTA005	KENT AUTOMOTIVE	TURNED EYEBOLT ZINC	\$52.88	P 28332	05/07/26	05/07/26	05/07/26				
26-01015	1	KEENC005	KEEN COMPRESSED GAS COMPANY	VARIOUS GAS CYLINDERS	\$88.80	P 28331	05/07/26	05/07/26	05/07/26	83577746			
26-01057	1	NAPAA005	NAPA AUTO PARTS #38807306	#37 EXPLORER CLASS3 BALL MOUNT	\$22.54	P 28355	05/12/26	05/12/26	05/13/26	374530			
26-01057	2	NAPAA005	NAPA AUTO PARTS #38807306	BATTERY FOR MOWER	\$77.85	P 28355	05/12/26	05/12/26	05/13/26	375416			
26-01057	3	NAPAA005	NAPA AUTO PARTS #38807306	BELT 5V 5/8" X 199"	\$380.64	P 28355	05/12/26	05/12/26	05/13/26	375740			
26-01057	4	NAPAA005	NAPA AUTO PARTS #38807306	ETHANOL TRTMT	\$36.24	P 28355	05/12/26	05/12/26	05/13/26	375995			
26-01057	5	NAPAA005	NAPA AUTO PARTS #38807306	CORE DEPOSIT RETURN	38.00-	P 28355	05/12/26	05/12/26	05/13/26	376300			
26-01057	6	NAPAA005	NAPA AUTO PARTS #38807306	TRAILER LIGHT	\$57.12	P 28355	05/12/26	05/12/26	05/13/26	376485			
26-01057	7	NAPAA005	NAPA AUTO PARTS #38807306	55 DEF. STAIN EXTRACTOR,BRUSH	\$289.06	P 28355	05/12/26	05/12/26	05/13/26	378047			
26-01057	9	NAPAA005	NAPA AUTO PARTS #38807306	FREON 134A REFRIGERANT	\$349.99	P 28355	05/12/26	05/12/26	05/13/26	378602			
26-01057	10	NAPAA005	NAPA AUTO PARTS #38807306	#14 BREAK AWAY SYSTEM	\$72.32	P 28355	05/12/26	05/12/26	05/13/26	378869			
26-01057	11	NAPAA005	NAPA AUTO PARTS #38807306	R134A PA	\$27.70	P 28355	05/12/26	05/12/26	05/13/26	379035			
26-01057	12	NAPAA005	NAPA AUTO PARTS #38807306	TRAILER-LUBE PLUG, OIL BATH HU	\$129.61	P 28355	05/12/26	05/12/26	05/13/26	379514			
26-01057	13	NAPAA005	NAPA AUTO PARTS #38807306	PX THREAD SEALANT	\$22.16	P 28355	05/12/26	05/12/26	05/13/26	380090			
26-01057	14	NAPAA005	NAPA AUTO PARTS #38807306	TRAILER #2 BREAK AWAY SYSTEM,P	\$76.81	P 28355	05/12/26	05/12/26	05/13/26	380297			
26-01057	15	NAPAA005	NAPA AUTO PARTS #38807306	PLUG	\$1.89	P 28355	05/12/26	05/12/26	05/13/26	380755			
26-01068	1	ASSOC005	ASSOCIATED TRUCK PARTS	CHROME HUB CAP	\$113.40	P 28345	05/12/26	05/12/26	05/13/26	07P22337			
26-01091	1	KEENC005	KEEN COMPRESSED GAS COMPANY	CO2 10% ARGON CYLNDER-WELDING	\$94.60	P 28351	05/13/26	05/13/26	05/13/26	0031452115			
26-01110	1	TONYS005	TONY'S EMERGENCY SERVICES	TK #5 REMOVE & REPLACE LIGHTS	\$475.00	P 28386	05/19/26	05/19/26	05/20/26	1523			
26-01112	1	NULLS005	NULLS SALES & SERVICE	STRAPS, SNCHOR SHACKLE TWIST L	\$1,502.55	P 28380	05/19/26	05/19/26	05/20/26	25016			
26-01114	1	TPTRA005	T.P. TRAILERS, INC	CUSTOM DRAW LATCH W/ FOLDABLE	\$336.64	P 28387	05/19/26	05/19/26	05/20/26	501368			
26-01115	1	KENTA005	KENT AUTOMOTIVE	MECHANIC WIRE 16 GAUGE,BRASS F	\$983.71	P 28375	05/19/26	05/19/26	05/20/26	9313457691			
26-01120	1	HUNTE005	HUNTER KEYSTONE PETERBILT L.P.	(BW) VALVE-QUICK RELEASE	\$63.44	P 28373	05/19/26	05/19/26	05/20/26	Y201205073:01			
26-01121	1	HUNTE005	HUNTER KEYSTONE PETERBILT L.P.	TK#45 WS-24 WHEEL SPEED SENSOR	\$82.86	P 28373	05/19/26	05/19/26	05/20/26	Y201196778:01			
26-01122	1	HUNTE005	HUNTER KEYSTONE PETERBILT L.P.	TK # 45 KIT, TURBO ACTUATOR	\$1,998.90	P 28373	05/19/26	05/19/26	05/20/26	Y201203563:01			
26-01122	2	HUNTE005	HUNTER KEYSTONE PETERBILT L.P.	CREDIT FOR CORE KIT, TURBO ACT	250.00-	P 28373	05/19/26	05/19/26	05/20/26	Y201206084:01			
26-01122	3	HUNTE005	HUNTER KEYSTONE PETERBILT L.P.	CREDIT FOR REMAN SHOE KIT	105.00-	P 28373	05/19/26	05/19/26	05/20/26	Y201199875:01			
26-01139	1	COMMO010	COMMONWEALTH OF PENNSYLVANIA	APP OF CORRECTION OF VEHICLE R	\$72.00	P 28362	05/19/26	05/19/26	05/20/26	050726			
26-01140	1	TONYS005	TONY'S EMERGENCY SERVICES	TK # 45,46,47,48,49,50,51 REMO	\$1,725.00	P 28386	05/19/26	05/19/26	05/20/26	1514			
26-01141	1	TONYS005	TONY'S EMERGENCY SERVICES	TK # 7 ADD ON (2) LEDS ON REAR	\$415.00	P 28386	05/19/26	05/19/26	05/20/26	1517			
26-01142	1	TONYS005	TONY'S EMERGENCY SERVICES	TK # 6 REMOVE EQIP FROM OLD TR	\$1,150.00	P 28386	05/19/26	05/19/26	05/20/26	1515			
26-01166	1	KENTA005	KENT AUTOMOTIVE	COUPLER PLUG, NPT PLUG	\$49.85	P 28375	05/20/26	05/20/26	05/20/26	9313465507			
26-01168	1	LITTL005	LITTLE INC., ROBERT E.	NEEDLE CAGE, WORM GEAR, FILTER	\$617.39	P 28376	05/20/26	05/20/26	05/20/26	03-1264286			
26-01171	1	COLLI010	COLLIFLOWER INC.	TK # 53 3/8 ANCHOR COUP	\$74.34	P 657	05/26/26	05/26/26	05/26/26	3000806			
26-01171	2	COLLI010	COLLIFLOWER INC.	EARLY PAY DISCOUNT	0.74-	P 657	05/26/26	05/26/26	05/26/26	3000806			

East Goshen Township  
Purchase Order Listing By Expenditure Account

Expenditure Account		Description										
P.O. Id	Item	Vendor Id	Vendor Name	Item Description	Amount	Stat/Chk	First Enc Date	Rcvd Date	Chk/Void Date	Invoice	PO Type	
					<b>\$11,763.93</b>							
01-433-2450			MATERIALS & SUPPLIES - SIGNS									
26-01164	1	WEIGA005	WEIGAND INC., H.A.	30" R1-1,36"W3-2,9" FLAT SIGN	\$1,548.00	P 28390	05/20/26	05/20/26	05/20/26	127525		
01-433-2470			UTILITIES - TRAFFIC LIGHTS									
26-00980	2	PECO0020	PECO - 2823930100	2823930100 2/24/26- 3/25/26	\$801.11	P 653	05/01/26	05/01/26	05/01/26	040826		
			Tracking Id: LIQFUEL	LIQUID FUEL PURCHASES								
01-433-2500			MAINT. REPAIRS.TRAFF.SIG.									
26-00993	1	HIGGI010	HIGGINS & SONS INC., CHARLES A	TRAFFIC LGT MAINT-1397 PAOLI P	\$200.00	P 28327	05/06/26	05/06/26	05/07/26	64714		
			Tracking Id: LIQFUEL	LIQUID FUEL PURCHASES								
26-01006	1	HIGGI010	HIGGINS & SONS INC., CHARLES A	TRAFFIC LGT MAINT-RT 3 &WESTOW	\$5,200.00	P 28327	05/07/26	05/07/26	05/07/26			
			Tracking Id: LIQFUEL	LIQUID FUEL PURCHASES								
26-01007	1	HIGGI010	HIGGINS & SONS INC., CHARLES A	TRAFFIC LGT MAINT-STRASBURG &E	\$1,296.75	P 28327	05/07/26	05/07/26	05/07/26	64665		
			Tracking Id: LIQFUEL	LIQUID FUEL PURCHASES								
26-01008	1	HIGGI010	HIGGINS & SONS INC., CHARLES A	TRAFFIC LGT MAINT-RESERVOIR &P	\$275.00	P 28327	05/07/26	05/07/26	05/07/26	64679		
			Tracking Id: LIQFUEL	LIQUID FUEL PURCHASES								
26-01060	1	HIGGI010	HIGGINS & SONS INC., CHARLES A	TRAFFIC LGT MAINT-N. CHESTER R	\$569.00	P 28350	05/12/26	05/12/26	05/13/26	64727		
			Tracking Id: LIQFUEL	LIQUID FUEL PURCHASES								
26-01133	1	HIGGI010	HIGGINS & SONS INC., CHARLES A	TRAFFIC LGT MAINT-352 &PAOLI	\$182.00	P 28371	05/19/26	05/19/26	05/20/26	64759		
26-01134	1	HIGGI010	HIGGINS & SONS INC., CHARLES A	TRAFFIC LGT MAINT-PAOLI & RESE	\$275.00	P 28371	05/19/26	05/19/26	05/20/26	64757		
					<b>\$7,997.75</b>							
01-434-3610			STREET LIGHTING									
26-00980	1	PECO0020	PECO - 2823930100	2823930100 2/24/26- 3/25/26	\$853.59	P 653	05/01/26	05/01/26	05/01/26	040826		
			Tracking Id: LIQFUEL	LIQUID FUEL PURCHASES								
01-436-2450			STORMWATER MATERIALS & SUPPLIES									
26-01005	1	HIGHW005	HEIDELBERG MATERIALS	2.97 TON 9.5MM 0.3<30 20R H PG	\$209.83	P 28328	05/07/26	05/07/26	05/07/26	4819707		
			Tracking Id: LIQFUEL	LIQUID FUEL PURCHASES								
26-01059	1	MAINL010	MAIN LINE CONCRETE	4 YD CONCRETE 4000 PSI & DELIV	\$1,000.00	P 28353	05/12/26	05/12/26	05/13/26	566182		

East Goshen Township  
Purchase Order Listing By Expenditure Account

Expenditure Account		Description						First Enc	Rcvd	Chk/Void	PO
P.O. Id	Item	Vendor Id	Vendor Name	Item Description	Amount	Stat/Chk	Date	Date	Date	Invoice	Type
Tracking Id: LIQFUEL		LIQUID FUEL PURCHASES									
26-01067	1	MAINL010	MAIN LINE CONCRETE	6 YD CONCRETE 4500 PSI & DELIV	\$1,358.00	P	28353	05/12/26	05/12/26	05/13/26	
Tracking Id: LIQFUEL		LIQUID FUEL PURCHASES									
26-01092	1	DISTE092	DISTEFANO LANDSCAPE SERVICES	51 YDS SCREENED TOP SOIL	\$637.50	P	28347	05/13/26	05/13/26	05/13/26	32927
Tracking Id: LIQFUEL		LIQUID FUEL PURCHASES									
26-01143	1	HIGHW005	HEIDELBERG MATERIALS	32.93 TON 9.5MM 0.3<30 20R H P	\$1,612.47	P	28372	05/19/26	05/19/26	05/20/26	4826582
Tracking Id: LIQFUEL		LIQUID FUEL PURCHASES									
26-01159	1	MAINL010	MAIN LINE CONCRETE	7 YD CONCRETE 4000 PSI & DELIV	\$1,555.00	P	28379	05/20/26	05/20/26	05/20/26	566266
Tracking Id: LIQFUEL		LIQUID FUEL PURCHASES									
26-01160	1	GAPPO005	GAP POWER RENTALS PLUS LLC	MARGIN TROWEL, GAUGING TROWEL,	\$147.75	P	28366	05/20/26	05/20/26	05/20/26	2116322
Tracking Id: LIQFUEL		LIQUID FUEL PURCHASES									
26-01160	2	GAPPO005	GAP POWER RENTALS PLUS LLC	EARLY PAY DISCOUNT	1.48-	P	28366	05/20/26	05/20/26	05/20/26	2116322
Tracking Id: LIQFUEL		LIQUID FUEL PURCHASES									
					<b>\$6,519.07</b>						
01-436-3840		STORMWATER EQUIPMENT RENTAL									
26-01118	1	FOLEY005	FOLEY INC.	CAT 316 SM HYDRAULIC EXCAVATOR	\$4,825.00	P	28364	05/19/26	05/19/26	05/20/26	INV0774408
Tracking Id: LIQFUEL		LIQUID FUEL PURCHASES									
26-01119	1	FOLEY005	FOLEY INC.	CAT 305-07 CR MINI HYD EXCAVAT	\$6,175.00	P	28364	05/19/26	05/19/26	05/20/26	INV0787952
Tracking Id: LIQFUEL		LIQUID FUEL PURCHASES									
					<b>\$11,000.00</b>						
01-437-2460		GENERAL EXPENSE - SHOP									
26-01037	1	LOWES005	LOWES BUSINESS ACCOUNT/GECF	VARIOUS PURCHASES- SEE NOTES	\$395.97	P	658	05/07/26	05/07/26	05/07/26	041726
26-01037	4	LOWES005	LOWES BUSINESS ACCOUNT/GECF	VARIOUS PURCHASES- SEE NOTES	\$113.96	P	658	05/07/26	05/07/26	05/07/26	041726
26-01037	6	LOWES005	LOWES BUSINESS ACCOUNT/GECF	VARIOUS PURCHASES- SEE NOTES	\$87.90	P	658	05/07/26	05/07/26	05/07/26	041726
26-01037	7	LOWES005	LOWES BUSINESS ACCOUNT/GECF	VARIOUS PURCHASES- SEE NOTES	\$86.98	P	658	05/07/26	05/07/26	05/07/26	041726
26-01083	1	SMITH010	SMITH, SUE	REIMBURSE EXPENSES TO CLEAN BU	\$92.76	P	28358	05/13/26	05/13/26	05/13/26	051126
					<b>\$777.57</b>						
01-437-2600		SHOP - TOOLS									
26-01004	1	GRAIN005	GRAINGER	NUT DRIVER SETS, TOOL BACKPACK	\$261.24	P	28324	05/07/26	05/07/26	05/07/26	9876859506

**East Goshen Township**  
Purchase Order Listing By Expenditure Account

Expenditure Account		Description											
P.O. Id	Item	Vendor Id	Vendor Name	Item Description	Amount	Stat/Chk	First Enc Date	Rcvd Date	Chk/Void Date	Invoice	PO Type		
01-438-2450		MATERIALS & SUPPLIES-HIGHWAYS											
26-01011	1	HIGHW005	HEIDELBERG MATERIALS	12.06 TON 9.5MM 0.3<30 20R H P	\$852.04	P 28328	05/07/26	05/07/26	05/07/26	4825276			
				Tracking Id: LIQFUEL LIQUID FUEL PURCHASES									
26-01092	2	DISTE092	DISTEFANO LANDSCAPE SERVICES	51 YDS SCREENED TOP SOIL	\$637.50	P 28347	05/13/26	05/13/26	05/13/26	32927			
				Tracking Id: LIQFUEL LIQUID FUEL PURCHASES									
26-01143	2	HIGHW005	HEIDELBERG MATERIALS	32.93 TON 9.5MM 0.3<30 20R H P	\$350.42	P 28372	05/19/26	05/19/26	05/20/26	4826582			
				Tracking Id: LIQFUEL LIQUID FUEL PURCHASES									
					<b>\$1,839.96</b>								
01-438-2460		TREE REMOVAL											
26-01111	1	HARLA010	HARLAN TREE SERVICE	REMOVE (4) TREES IN VARIOUS LO	\$4,100.00	P 28369	05/19/26	05/19/26	05/20/26	006811			
				Tracking Id: LIQFUEL LIQUID FUEL PURCHASES									
01-438-3840		EQUIPMENT RENTAL											
26-01117	1	FOLEY005	FOLEY INC.	CAT CS10GC CAB/AC RENTAL	\$2,125.00	P 28364	05/19/26	05/19/26	05/20/26	INV0778342			
				Tracking Id: LIQFUEL LIQUID FUEL PURCHASES									
26-01119	2	FOLEY005	FOLEY INC.	CREDIT FOR CAT CS10GC RENTAL	5,325.00-	P 28364	05/19/26	05/19/26	05/20/26	CRD0072412			
				Tracking Id: LIQFUEL LIQUID FUEL PURCHASES									
					<b>3,200.00-</b>								
01-452-2025		SUMMER PROGRAM GENERAL EXPENSE											
26-01079	1	DAILY005	DAILY CONNECT	PROFESSIONAL CAMP APP- 3 MNTHS	\$1,012.20	P 28346	05/13/26	05/13/26	05/13/26	ZWGPRJXV-0002			
26-01130	1	FUENT005	FUENTES, MELINA	REIMBURSE RE: FBI BACKGROUND C	\$24.95	P 28365	05/19/26	05/19/26	05/20/26	050826			
26-01161	1	COMP005	COMPASS HARDWOODS LLC	PLYWOOD & WOOD FOR SUMMER REC	\$1,080.04	P 28363	05/20/26	05/20/26	05/20/26	16357			
					<b>\$2,117.19</b>								
01-452-3203		CAMP OUT EVENT											
26-01026	1	BIGAI005	BIG AIR CINEMA	MOVIE PROJECTION SYSTEM RENTAL	\$1,200.00	P 28318	05/07/26	05/07/26	05/07/26	MT-1261			
01-452-3204		COMMUNITY DAY											
26-01037	9	LOWES005	LOWES BUSINESS ACCOUNT/GECF	VARIOUS PURCHASES- SEE NOTES	\$195.43	P 658	05/07/26	05/07/26	05/07/26	041726			
26-01037	10	LOWES005	LOWES BUSINESS ACCOUNT/GECF	VARIOUS PURCHASES- SEE NOTES	\$31.80	P 658	05/07/26	05/07/26	05/07/26	041726			
26-01165	1	GRAPH005	GRAPHIC IMPRESSIONS OF AMERICA	AMERICA 250 POLOS & TSHIRTS	\$2,963.46	P 28367	05/20/26	05/20/26	05/20/26	26-7152			
					<b>\$3,190.69</b>								

East Goshen Township  
Purchase Order Listing By Expenditure Account

Expenditure Account		Description									
P.O. Id	Item	Vendor Id	Vendor Name	Item Description	Amount	Stat/Chk	First Enc Date	Rcvd Date	Chk/Void Date	Invoice	PO Type
01-452-3601			MISCELLANEOUS EVENTS								
26-01002	1	HELPU005	HELP-U-BRIDGE LLC	WHEELCHAIR BASKETBALL PROGRAM	\$450.00	P 28326	05/07/26	05/07/26	05/07/26	1017	
01-452-3701			LADIES & YOUTH TENNIS								
26-01028	1	JUSTT005	JUST TENNIS LLC.	TENNIS INSTRUCTION	\$2,544.00	P 28330	05/07/26	05/07/26	05/07/26	260	
01-452-3712			YOGA EXPENSE								
26-01090	1	EVANG005	EVANGELISTA, CHARO	2026 SUMMER YOGAFLOW & GENTLE	\$2,227.00	P 28348	05/13/26	05/13/26	05/13/26	7127	
01-452-3730			PICKLEBALL								
26-01028	2	JUSTT005	JUST TENNIS LLC.	PICKLEBALL INSTRUCTION	\$4,972.00	P 28330	05/07/26	05/07/26	05/07/26	260	
01-454-2460			TREE REMOVAL-PARK								
26-01017	1	STUMP005	STUMP WORKS, LLC	9 STUMPS GROUND AND CLEANED UP	\$675.00	P 28342	05/07/26	05/07/26	05/07/26	1083	
01-454-3000			GENERAL EXPENSE								
26-00992	1	PORTA005	FUSIONSITE PENNSYLVANIA LLC	XL RESTROOM 4/27/26- 5/24/26	\$290.00	P 28337	05/06/26	05/06/26	05/07/26	PA46944	
26-01175	1	COMCA090	COMCAST 8499-10-109-0168581	0168581 5/9-6/8/26 PARK RR	\$274.94	P 659	05/26/26	05/26/26	05/26/26	050426	
					<b>\$564.94</b>						
01-454-3100			PROFESSIONAL SERVICES								
26-01127	6	JASPE005	JASPER PEST CONTROL, LLC	PEST CONTROL MARCH 2026	\$75.00	P 28374	05/19/26	05/19/26	05/20/26	2672	
01-454-3600			UTILITIES								
26-00976	1	PECO0030	PECO - 6957754000	6957754000 3/24-4/23 RESTROOM	\$438.03	P 654	05/01/26	05/01/26	05/01/26		
26-00977	1	PECO4005	PECO - 6240684000	6240684000 3/19-4/20/26 CHAMBE	\$102.93	P 656	05/01/26	05/01/26	05/01/26	042026	
26-01033	1	PECO0025	PECO - 0158016000	0158016000 3/27- 4/2/26 POND	\$106.57	P 659	05/07/26	05/07/26	05/07/26	042926	
26-01053	1	COMCA100	COMCAST 8499 10 109 0170322	0170322 5/1-5/31 PARK CAMERA	\$124.90	P 654	05/12/26	05/12/26	05/12/26	042626	
26-01100	1	PECO0035	PECO - 7652821222	7652821222 4/7-5/6/26 BOWTREE	\$69.63	P 666	05/18/26	05/18/26	05/18/26	050726	
26-01102	1	PECO5015	PECO - 5612868000	5612868000 3/30-4/29 MONTE VIS	\$287.31	P 668	05/18/26	05/18/26	05/18/26	043026	
					<b>\$1,129.37</b>						
01-454-3717			MARYDELL POND REHAB								
26-01036	1	PECO0050	PECO - 1896881222	1896881222 4/6-5/5/26 MARYDELL	\$79.26	P 661	05/07/26	05/07/26	05/07/26	050626	
01-454-3740			PARK MAINTENANCE & REPAIR								
26-00997	1	KENTA005	KENT AUTOMOTIVE	JOBBER DRILL BIT,EYEBOLT, NUT	\$271.88	P 28332	05/06/26	05/06/26	05/07/26	9313395282	
26-00999	1	JUDGE005	JUDGE MOBILE WASH	PRESSURE WASH EGT PAVILIONS	\$900.00	P 28329	05/07/26	05/07/26	05/07/26	45424	

East Goshen Township  
Purchase Order Listing By Expenditure Account

Expenditure Account		Description											
P.O. Id	Item	Vendor Id	Vendor Name	Item Description	Amount	Stat/Chk	First Enc Date	Rcvd Date	Chk/Void Date	Invoice	PO Type		
01-454-3740		PARK MAINTENANCE & REPAIR		Account Continued									
26-01037	2	LOWES005	LOWES BUSINESS ACCOUNT/GECF	VARIOUS PURCHASES- SEE NOTES	\$231.68	P 658	05/07/26	05/07/26	05/07/26	041726			
26-01037	5	LOWES005	LOWES BUSINESS ACCOUNT/GECF	VARIOUS PURCHASES- SEE NOTES	\$1,075.68	P 658	05/07/26	05/07/26	05/07/26	041726			
26-01058	1	MAINL010	MAIN LINE CONCRETE	1.5 YD CONCRETE 4000 PSI & DEL	\$537.50	P 28353	05/12/26	05/12/26	05/13/26	565074			
26-01132	2	WBMAS005	W.B.MASON CO.,INC.	TRASH BAGS, PAPER TOWELS, TOIL	\$196.50	P 28389	05/19/26	05/19/26	05/20/26	261691398			
26-01169	1	PATTE005	PATTERSON, MICHAEL J.	REPAIR PEDESTRIAN BRIDGE AT PA	\$2,283.00	P 28382	05/20/26	05/20/26	05/20/26	051526			
					<b>\$5,496.24</b>								
01-462-3100		PROFESSIONAL SERVICES											
26-01127	11	JASPE005	JASPER PEST CONTOL, LLC	PEST CONTROL MARCH 2026	\$75.00	P 28374	05/19/26	05/19/26	05/20/26	2672			
01-483-5315		PENSION - DC NON-UNIFORM											
26-01107	1	CHARL010	CHARLES SCHWAB FBO 7232-2184	MAY 2026 FBO 7232-2184	\$21,561.00	P 663	05/18/26	05/18/26	05/18/26	050126			
01-486-1560		HEALTH.ACCID. & LIFE											
26-00998	1	STAND005	STANDARD INSURANCE CO., THE	MAY 2026 PREMIUM	\$5,891.25	P 28340	05/06/26	05/06/26	05/07/26	041426			
26-01108	1	DELAW040	DELAWARE VALLEY HEALTH TRUST	MAY 2026 PREMIUM MED & DENTAL	\$85,999.09	P 664	05/18/26	05/18/26	05/18/26	31585			
					<b>\$91,890.34</b>								
01-486-3500		INSURANCE COVERAGE -PREM.											
26-00996	1	DLVWK005	DELAWARE VALLEY WORKERS'COMP.	WORKERS COMP Q2 2026 CONTRIB	\$53,012.50	P 28320	05/06/26	05/06/26	05/07/26	WCPREM26-EGOSH			
01-487-1910		UNIFORMS											
26-00987	1	GRAPH005	GRAPHIC IMPRESSIONS OF AMERICA	CLOTHING FOR BOS- ANN & LARRY	\$498.00	P 28325	05/06/26	05/06/26	05/07/26	26-7170A			
26-01030	2	CINTA005	CINTAS CORPORATION	UNIFORMS & MATS SETTLEMENT	\$11,242.03	P 28319	05/07/26	05/07/26	05/07/26	050526			
					<b>\$11,740.03</b>								
<b>Fund Total:</b>					<b>\$762,764.15</b>								
03-409-7400		CAPITAL REPLACEMENT-TWP BLDG											
26-01097	1	KAPPE005	KAPPE ASSOCIATES	TWP BLDG- HVAC GROUND WATER PU	\$7,246.00	P 1697	05/13/26	05/13/26	05/13/26	25-640-M2			
26-01152	1	PENNO005	PENNONI ASSOCIATES INC.	SERV THRU 032926 DIST CT RTU	\$780.50	P 1699	05/19/26	05/19/26	05/20/26	1322744			

**East Goshen Township**  
Purchase Order Listing By Expenditure Account

Expenditure Account		Description													
P.O. Id	Item	Vendor Id	Vendor Name	Item Description	Amount	Stat/Chk	First Enc Date	Rcvd Date	Chk/Void Date	Invoice	PO Type				
					<b>\$8,026.50</b>										
03-409-7450			CAPITAL PURCHASE - TWP BLDG												
26-01000	1	HAVERO05	HAVERFORD SYSTEMS	SIDE CONFERENCE RM- FINAL PYMT	\$5,366.96	P 1695	05/07/26	05/07/26	05/07/26	0073290					
26-01153	1	PENNO005	PENNONI ASSOCIATES INC.	SERV THRU 032926 VESTIBULE GLA	\$4,063.50	P 1699	05/19/26	05/19/26	05/20/26	1322746					
					<b>\$9,430.46</b>										
03-430-7400			CAPITAL REPLACEMENT - HWY EQUIP												
26-01013	1	KEENC005	KEEN COMPRESSED GAS COMPANY	MIG WELDER REPLACEMENT	\$4,807.64	P 1696	05/07/26	05/07/26	05/07/26	31448378					
		Tracking Id: LIQFUEL		LIQUID FUEL PURCHASES											
26-01057	8	NAPAA005	NAPA AUTO PARTS #38807306	MACHINE TO REPAIR A/C IN EQUIP	\$4,299.00	P 1698	05/12/26	05/12/26	05/13/26	378102					
		Tracking Id: LIQFUEL		LIQUID FUEL PURCHASES											
					<b>\$9,106.64</b>										
<b>Fund Total:</b>					<b>\$26,563.60</b>										
05-420-3600			C.C. METERS - UTILITIES												
26-00973	1	COMCA045	COMCAST 8499-10-109-0166205	0166205 4/21-5/20 THORNCROFT	\$258.89	P 992	04/30/26	04/30/26	04/30/26	041626					
26-00982	1	PECO1005	PECO - 1850703000	1850703000 3/30-4/29 WILSON AI	\$6.06	P 662	05/01/26	05/01/26	05/01/26	043026					
26-01040	1	PECO5005	PECO - 8279183000	8279183000 3/30-4/29 0 PAOLI P	\$6.06	P 665	05/07/26	05/07/26	05/07/26	043026					
					<b>\$271.01</b>										
05-420-3602			C.C. COLLECTION -UTILITIES												
26-00984	1	AQUAP015	AQUA PA 05	309826 0309826 3/19-4/21 TH	\$22.38	P 6582	05/06/26	05/06/26	05/07/26	042326 TH					
26-01034	1	PECO4010	PECO - 4541956000	4541956000 3/30-4/29 WESTTOWN	\$13.97	P 664	05/07/26	05/07/26	05/07/26	043026					
26-01039	1	PECO6005	PECO - 6488315000	6488315000 3/30-4/29 WILSON BO	\$6.06	P 666	05/07/26	05/07/26	05/07/26	043026					
26-01050	1	COMCA040	COMCAST 8499-10-085-0054593	0054593 4/28-5/27/26 HERSHEY	\$258.89	P 998	05/12/26	05/12/26	05/12/26	042326					
26-01104	1	PECO6010	PECO - 6928226000	6928226000 3/30-4/29 GREENHILL	\$503.00	P 671	05/18/26	05/18/26	05/18/26	043026					
					<b>\$804.30</b>										
05-420-3603			ASHBRIDGE - UTILITIES RECHARGE												
26-01052	1	COMCA035	COMCAST 8499-10-109-0165934	0165934 4/28-5/27/26 ASHBRIDGE	\$258.89	P 997	05/12/26	05/12/26	05/12/26	042326					
26-01099	1	PECO0040	PECO - 2270574000	2270574000 4/7-5/6/26 WYLLPENN	\$420.26	P 668	05/18/26	05/18/26	05/18/26	050726					

East Goshen Township  
Purchase Order Listing By Expenditure Account

Expenditure Account		Description									
P.O. Id	Item	Vendor Id	Vendor Name	Item Description	Amount	Stat/Chk	First Enc Date	Rcvd Date	Chk/Void Date	Invoice	PO Type
					<b>\$679.15</b>						
05-420-3604			MILL VAL/BARKWAY UTILITIES								
26-01051	1	COMCA030	COMCAST 8499-10-085-0054585	0054585 4/28-5/27/26 BARKWAY	\$258.89	P 996	05/12/26	05/12/26	05/12/26	042326	
26-01103	1	PECO5010	PECO - 5705362222	5705362222 3/30-4/29 BARKWAY	\$239.00	P 669	05/18/26	05/18/26	05/18/26		
					<b>\$497.89</b>						
05-420-3701			C.C. INTERCEPT-MAINT.&REP								
26-01087	1	LECLE005	LEC - LENNI ELECTRIC CORPORATI	TROUBLESHIT FLOW METER NOT OPE	\$272.37	P 6590	05/13/26	05/13/26	05/13/26	260503	
05-420-3702			C.C. COLLEC.-MAINT.& REPR.								
26-01063	1	LECLE005	LEC - LENNI ELECTRIC CORPORATI	BARKWAY PUMP ST- PUMP REMOVAL	\$216.00	P 6590	05/12/26	05/12/26	05/13/26	260444	
26-01064	1	LECLE005	LEC - LENNI ELECTRIC CORPORATI	ASHBRIDGE PUMP ST-PUMP REMOVAL	\$216.00	P 6590	05/12/26	05/12/26	05/13/26	260443	
26-01095	1	KAPPE005	KAPPE ASSOCIATES	ASHBRIDGE PUMP ST- MISSION ALA	\$7,246.00	P 6589	05/13/26	05/13/26	05/13/26	25-640-M4	
26-01096	1	KAPPE005	KAPPE ASSOCIATES	BARKWAY PUMP ST- MISSION ALARM	\$7,246.00	P 6589	05/13/26	05/13/26	05/13/26	25-640-M3	
26-01116	1	FOLEY005	FOLEY INC.	CAT 315 SM HYDRAULIC EXCAVATOR	\$4,825.00	P 6594	05/19/26	05/19/26	05/20/26	INV0792543	
26-01135	1	NEWEN005	NEW ENTERPRISE STONE & LIME IN	STONE, 2A & AASHTO #57 94.01 T	\$5,683.65	P 6598	05/19/26	05/19/26	05/20/26	8801187	
					<b>\$25,432.65</b>						
05-420-3705			ASHBRIDGE-MAINT.&REPR								
26-01127	5	JASPE005	JASPER PEST CONTROL, LLC	PEST CONTROL MARCH 2026	\$25.00	P 6595	05/19/26	05/19/26	05/20/26	2672	
05-420-3706			BARKWAY -MAINT.& REPR.								
26-01127	1	JASPE005	JASPER PEST CONTROL, LLC	PEST CONTROL MARCH 2026	\$25.00	P 6595	05/19/26	05/19/26	05/20/26	2672	
05-422-2440			R.C. STP- CHEMICALS								
26-00994	1	MAINP005	MAIN POOL & CHEMICAL COMP. INC	1100 GALS ALMN SULFATE 48%	\$2,442.00	P 6584	05/06/26	05/06/26	05/07/26	6117034	
26-00995	1	MAINP005	MAIN POOL & CHEMICAL COMP. INC	1430 GALS ALMN SULFATE 48%	\$3,174.60	P 6584	05/06/26	05/06/26	05/07/26	6117112	
26-01014	1	MAINP005	MAIN POOL & CHEMICAL COMP. INC	1500 GALS SODIUM HYDROXIDE 25%	\$2,790.00	P 6584	05/07/26	05/07/26	05/07/26	6117197	
26-01066	1	MAINP005	MAIN POOL & CHEMICAL COMP. INC	1450 GALS ALMN SULFATE 48%	\$3,219.00	P 6591	05/12/26	05/12/26	05/13/26	6117309	
26-01138	1	MAINP005	MAIN POOL & CHEMICAL COMP. INC	1500 GALS SODIUM HYDROXIDE 50%	\$2,790.00	P 6597	05/19/26	05/19/26	05/20/26	6117458	
					<b>\$14,415.60</b>						
05-422-3600			R.C STP -UTILITIES								
26-01056	1	FIOS0005	VERIZON - PW FIOS 0001-15	4/28/26- 5/27/26 PW FIOS	\$54.00	P 999	05/12/26	05/12/26	05/12/26	042726	



**East Goshen Township**  
Purchase Order Listing By Expenditure Account

Expenditure Account		Description											
P.O. Id	Item	Vendor Id	Vendor Name	Item Description	Amount	Stat/Chk	First Enc Date	Rcvd Date	Chk/Void Date	Invoice	PO Type		
05-422-4500			R.C. STP-CONTRACTED SERV.	Account Continued									
26-01025	1	SUBUR010	SPL, INC- READING	LABTESTING RCSTP APRIL 2026	\$2,123.54	P 6586	05/07/26	05/07/26	05/07/26	6038P2601457			
26-01098	1	BIGFI005	BIG FISH ENVIRONMENTAL SERVICE	SERVICES RE: RCSTP- APRIL 2026	\$27,832.84	P 667	05/18/26	05/18/26	05/18/26	26-0430			
					<b>\$29,956.38</b>								
05-422-4502			R.C. SLUDGE-LAND CHESTER										
26-00971	1	CCSOL005	C.C. SOLID WASTE AUTHORITY	WEEK 4/8/2026- 4/15/2026	\$735.25	P 991	04/30/26	04/30/26	04/30/26	78280			
26-01054	1	CCSOL005	C.C. SOLID WASTE AUTHORITY	WEEK 4/16/2026- 4/22/2026	\$781.15	P 995	05/12/26	05/12/26	05/12/26	78365			
26-01154	1	BLOSE005	BLOENSKI DISPOSAL CO, CHARLES	SWITCH 20 YD W/ LINER 042726	\$329.50	P 6592	05/19/26	05/19/26	05/20/26	192782			
26-01158	1	BLOSE005	BLOENSKI DISPOSAL CO, CHARLES	SWITCH 20 YD W/ LINER 050426	\$329.50	P 6592	05/20/26	05/20/26	05/20/26	192850			
26-01178	1	CCSOL005	C.C. SOLID WASTE AUTHORITY	WEEK 4/23/2026- 4/30/2026	\$612.85	P 1002	05/26/26	05/26/26	05/26/26	78443			
					<b>\$2,788.25</b>								
05-429-2600			ADMIN.-COMPUTER EXPENSES										
26-00974	2	VERIZ040	VERIZON - 542413545-00001	3/22-4/21/26 MULT.TWP CELL PHO	\$80.02	P 994	04/30/26	04/30/26	04/30/26	6141656560			
26-01176	1	COMCA025	COMCAST 8499-10-109-0111284	0111284 5/9-6/8/26 SPEC VID	\$74.81	P 1003	05/26/26	05/26/26	05/26/26				
					<b>\$154.83</b>								
05-429-3210			ADMIN.- COMMUNICATION EXPENSE										
26-01088	1	FIRST025	FIRSTNET - #287338201667	APRIL 2026	\$152.92	P 6588	05/13/26	05/13/26	05/13/26	05082026			
<b>Fund Total:</b>					<b>\$115,518.88</b>								
06-427-4500			CONTRACTED SERV.										
26-01048	1	AJBAJ005	AJB A.J. BLOENSKI INC.	RESIDENTIAL PICKUP MAY 2026	\$88,194.81	P 797	05/12/26	05/12/26	05/12/26	2811754W360			
06-427-4502			LANDFILL FEES										
26-00971	2	CCSOL005	C.C. SOLID WASTE AUTHORITY	WEEK 4/8/2026- 4/15/2026	\$7,203.21	P 796	04/30/26	04/30/26	04/30/26	78280			
26-01054	2	CCSOL005	C.C. SOLID WASTE AUTHORITY	WEEK 4/16/2026- 4/22/2026	\$7,874.94	P 798	05/12/26	05/12/26	05/12/26	78365			
26-01178	2	CCSOL005	C.C. SOLID WASTE AUTHORITY	WEEK 4/23/2026- 4/30/2026	\$8,054.94	P 799	05/26/26	05/26/26	05/26/26	78443			
					<b>\$23,133.09</b>								
06-427-4504			RECYCLING FEES										
26-01157	1	TOTAL010	TOTAL RECYCLE INC.	RECYCLING FEES APRIL 2026	\$3,887.15	P 948	05/20/26	05/20/26	05/20/26	18719			
<b>Fund Total:</b>					<b>\$115,215.05</b>								

**East Goshen Township**  
Purchase Order Listing By Expenditure Account

Expenditure Account		Description									
P.O. Id	Item	Vendor Id	Vendor Name	Item Description	Amount	Stat/Chk	First Enc Date	Rcvd Date	Chk/Void Date	Invoice	PO Type
07-424-3110			MUNIC.AUTH.-AUDITING								
26-01071	1	MAILL005	MAILLIE LLP	FINAL BILLING AUDIT EGT MUA	\$4,500.00	P 3592	05/13/26	05/13/26	05/13/26	127792	
07-424-3130			ENGINEERING SERVICES								
26-01073	1	PENNO005	PENNONI ASSOCIATES INC.	SERV THRU 041926 MORSTEIN RD	\$1,064.00	P 3593	05/13/26	05/13/26	05/13/26	1323178	
26-01075	1	PENNO005	PENNONI ASSOCIATES INC.	SERV THRU 041926 2026 GEN SERV	\$3,973.25	P 3593	05/13/26	05/13/26	05/13/26	1323180	
26-01076	1	PENNO005	PENNONI ASSOCIATES INC.	SERV THRU 041926 25 CHAPTER 94	\$1,220.50	P 3593	05/13/26	05/13/26	05/13/26	1323181	
26-01077	1	PENNO005	PENNONI ASSOCIATES INC.	SERV THRU 041926 RCSTP NPDES	\$1,662.50	P 3593	05/13/26	05/13/26	05/13/26	1323182	
					<b>\$7,920.25</b>						
07-424-3705			HUNT COUNTY ENGINEERING								
26-01072	1	PENNO005	PENNONI ASSOCIATES INC.	SERV THRU 041926 HUNT CTRY PUM	\$3,354.00	P 3593	05/13/26	05/13/26	05/13/26	1323177	
07-429-3700			CHESTER CREEK CAPITAL								
26-01074	1	PENNO005	PENNONI ASSOCIATES INC.	SERV THRU 041926 WATERVIEW PIP	\$2,663.50	P 3593	05/13/26	05/13/26	05/13/26	1323179	
			<b>Fund Total:</b>		<b>\$18,437.75</b>						
12-454-3740			PARK MAINTENANCE & REPAIR								
26-01009	1	ARMBR010	ARM BRICKHOUSE	MARCH 2026 WATER SAMPLING	\$402.79	P 1345	05/07/26	05/07/26	05/07/26	28264	
26-01113	1	ARMBR010	ARM BRICKHOUSE	APRIL 2026 WATER SAMPLING	\$473.30	P 1346	05/19/26	05/19/26	05/20/26	0028667	
					<b>\$876.09</b>						
			<b>Fund Total:</b>		<b>\$876.09</b>						

**Total Charged Lines: 270 Total List Amount: \$1,039,375.52 Total Void Amount: \$0.00**

**East Goshen Township**  
Purchase Order Listing By Expenditure Account

<b>Totals by Year-Fund</b>						
<b>Fund Description</b>	<b>Fund</b>	<b>Expend Total</b>	<b>DEBT SERVICE</b>	<b>CREDIT CARD</b>	<b>ACH</b>	<b>REVISED TOTAL</b>
	6-01	\$762,764.15		21,704.64	305.75	784,774.54
	6-03	\$26,563.60		85.00	115.00	26,763.60
	6-05	\$115,518.88	15,367.37	240.78	115.00	131,242.03
	6-06	\$115,215.05			57.50	115,272.55
	6-07	\$18,437.75				18,437.75
	6-12	\$876.09				876.09
<b>Total Of All Funds:</b>		<u>\$1,039,375.52</u>				1,077,366.56

Less Municipal Authority:	-18,437.75		-18,437.75
---------------------------	------------	--	------------

<b>Total Board Approval:</b>			<b>\$1,058,928.81</b>
------------------------------	--	--	-----------------------

**ACH DEBITS TO GENERAL FUNDS**

**EXPENSE REPORT**

*Attachment 2 OF 2*

**Meeting Date**

**6/2/2026**

*4/1/2026- 4/30/2026*

<u>Fund</u>	<u>Fee Charged</u>	<u>Name</u>	<u>Month Covered</u>	<u>Description</u>
01 GENERAL FUND	18.25 <u>287.50</u>	MERCH BNKCD FEES M&T MONTHLY FEE	April 2026 April 2026	CRED.CARD BANK CHARGES POSITIVE PAY & ACH MONITOR
	<b>\$305.75</b>			
03 CAPITAL RESERVE	115.00 <u>115.00</u>	M&T MONTHLY FEE	April 2026	POSITIVE PAY & ACH MONITOR
	<b>\$115.00</b>			
05 SEWER FUND	115.00 <u>115.00</u>	M&T MONTHLY FEE	April 2026	POSITIVE PAY & ACH MONITOR
	<b>\$115.00</b>			
06 REFUSE FUND	57.50 <u>57.50</u>	M&T MONTHLY FEE	April 2026	POSITIVE PAY & ACH MONITOR
	<b>\$57.50</b>			
<b>TOTAL</b>	<u><b>\$593.25</b></u>			

EAST GOSHEN TOWNSHIP  
MONTHLY DEBT PAYMENT BREAKDOWN  
May 25, 2026

**GENERAL FUND:**

Interest rate	Interest payment	Principal payment	Year of Issuance	Loan Description	Original loan amount	Remaining Principal	Retirement Date
	\$0.00	\$0.00	<b>2003</b>	Multi purpose 9 projects	\$5,500,000.00	\$0.00	2023
2.7%	\$0.00	\$0.00	<b>2017</b>	G Playground , Dams, & Paoli Pike Trail	\$5,310,000.00	\$4,630,000.00	2037

**SEWER FUND:**

Interest rate	Interest payment	Principal payment	Year of Issuance	Loan Description	Original loan amount	Remaining Principal	Retirement Date
4.0%	\$12,338.70	\$0.00	<b>2008</b>	RCSTP Expansion	9,500,000.00	\$3,739,000.00	2032
3.1%	\$3,028.67	\$0.00	<b>2013</b>	Diversion Projects	2,500,000.00	\$1,192,000.00	2033
2.7%	\$0.00	\$0.00	<b>2017</b>	S West Goshen STP	2,840,000.00	\$1,940,000.00	2037

## 6/2/2026 ATTACHMENT 1 OF 2

## PLGIT 1107.1010

DATE	DESCRIPTION	TOTAL
	<b>DEREK DAVIS</b>	
3/27/2026	CC PSATS- CONFERENCE CANCELATON FOR M. MILLER	-149.00
4/1/2026	CC W3 GLOBAL SOLUTIONS- QTR 2 2026 WEB SERVICE	900.00
4/2/2026	CC WIGGINS SHREDDING- EMPTY SHREDDING BIN EVERY 8 WEEKS	78.00
4/2/2026	CC INDEED- MARCH 2026 SPONSORED JOB AD- STAFF ACCOUNTANT & PERMIT COORDINATOR	350.04
4/5/2026	CC AMAZON.COM- DELL LAPTOP CHARGER FOR M.MILLER	21.46
4/5/2026	CC AMAZON.COM- HDMI TO VGA WIRE FOR C. BRYAN COMPUTER	11.95
4/6/2026	CC MICROSOFT.COM-MICROSOFT SUBSCRIPTION FOR MULTIPLE PEOPLE- MONTHLY- 4/5/2026- 5/4/2026	590.79
4/10/2026	CC AMAZON.COM- PACKING TAPE AND MEDIUM BINDER CLIPS	31.81
4/10/2026	CC AMAZON.COM- MAGNETIC DRY ERASE WHITEBOARD FOR K. BROPHY	41.69
4/14/2026	CC ZOOM.COM- ZOOM ROOMS ANNUAL CHARGE PRORATED 4/14/26- 1/19/27	384.16
4/16/2026	CC MICROSOFT.COM-MICROSOFT SUBSCRIPTION FOR MULTIPLE PEOPLE- MONTHLY- 4/16/2026- 5/4/2026	3.99
4/19/2026	CC NFPA NATL FIRE PROTECT- NFPA ANNUAL MEMBERSHIP FOR D. BRADY	225.00
4/20/2026	CC HOTEL HERHSEY RESTAURANT- BREAKFAST FOR EMPLOYEES THAT ATTENDED PSATS PLUS PUBLIC WORKS	870.80
4/21/2026	CC HOTEL HERSHEY- A. NOWAK ROOM FOR THE PSATS 2026 CONFERENCE & DINNER FOR D. GIEDER, K.KRAUSE, L.WERKHEIS	851.70
4/21/2026	CC HOTEL HERSHEY- D. GIEDER ROOM FOR THE PSATS 2026 CONFERENCE	574.98
4/21/2026	CC HOTEL HERSHEY- K. KRAUSE ROOM FOR THE PSATS 2026 CONFERENCE	862.47
4/21/2026	CC HOTEL HERSHEY- L. WERKHEISER ROOM FOR THE PSATS 2026 CONFERENCE	574.98
4/21/2026	CC HOTEL HERSHEY- D. DAVIS ROOM FOR THE PSATS 2026 CONFERENCE	574.98
4/22/2026	CC HOTEL HERSHEY- BOS ROOM FOR THE PSATS 2026 CONFERENCE & MEALS	1,028.49
4/22/2026	CC HOTEL HERSHEY- BOS ROOM FOR THE PSATS 2026 CONFERENCE & MEALS	1,052.92
		<b>\$8,881.21</b>

MARK MILLER		
3/26/2026	CC STOLTZFUS FARM SERVICE- WEED EATER	98.99
3/28/2026	CC AMAZON.COM- STEERING WHEEL COVER FOR FORD RANGER	15.99
4/1/2026	CC AMAZON.COM- BREAKROOM SUPPLIES- AA BATTERIES, CUPS	72.60
4/1/2026	CC AMAZON.COM- BREAKROOM SUPPLIES- 9INCH PLATES	27.58
4/1/2026	CC AMAZON.COM- BREAKROOM SUPPLIES- (4) IPHONSE CASES; ALUMN PANS	99.89
4/2/2026	CC SP BRUNT WORKWEAR- WORK BOOTS FOR MATT & BILY IN PW	371.84
4/2/2026	CC SQ*JSR DETAILING- 2019 F-350 TINT DRIVE'S SIDE WINDOW	115.00
4/5/2026	CC AMAZON.COM- LUNCH ROOM SUPPLIES- ALUMINUM PANS	78.54
4/6/2026	CC BESTBUY- TV FOR NEW ALARM SYSTEM, PUMP STATION PLANT OPERATION	190.79
4/7/2026	CC SUNOCO- DIESEL IN EGT TRUCK	186.82
4/9/2026	CC AMAZON.COM- EXTRA RAMM TO ACCOMMODATE MEMORY NEEDED TO RUN CAMERAS ON MARK'S COMPUTER	205.79
4/10/2026	CC PTC EZ PASS- AUTO RENEWAL FOR EZPASS	500.00
4/12/2026	CC AMAZON.COM- TK # 5 D-RINGS	179.76
4/12/2026	CC AMAZON.COM- TK # 14 SEAT COVERS	356.99
4/15/2026	CC APPLE.COM- ICLOUD CHAS LINDER FOR APRIL 2026	0.99
4/16/2026	CC INTERSTATE CHEMICAL CO- ETHANOL PROCOOL FOR HVAC SYSTEM	792.07
4/22/2026	CC AMAZON.COM- CAR AC LEAK DETECTION KIT, FORGED STEEL TOW EYE	53.98
4/25/2026	CC APPLE.COM- ICLOUD EDWARD (DUSTY) KILGORE FOR APRIL 2026	0.99
4/25/2026	CC APPLE.COM- ICLOUD MARK MILLER FOR APRIL 2026	0.99
		\$3,349.60

JASON LANG		
3/28/2026	CC GIANT- CANDY FOR EGG HUNT	16.92
3/28/2026	CC MAYDAY COFFEE & SHOP- COFFEE FOR THE EGG HUNT VOLUNTEERS	49.61
3/28/2026	CC IDENTOGO- FBI FEDERAL FINGERPRINTING CLEARANCE	25.95
4/1/2026	CC IN GSP SIGNS & BANNER- PICKLEBALL SIGNS	63.60
4/2/2026	CC AMAZON.COM- NEW DESK FOR J. WILHELMY	180.34
4/2/2026	CC APPLE.COM/BILL- MUSIC FOR AMERICA 250	10.59
4/2/2026	CC APPLE.COM/BILL- MUSIC FOR AMERICA 250	1.37
4/2/2026	CC AMAZON.COM- ACRYLIC PAINT FOR AMERICA 250	21.98
4/6/2026	CC AMAZON.COM- 100% COTTON FABRIC FOR AMERICA 250	11.39
4/7/2026	CC SPORTS UNLIMITED, INC- SALES TAX REFUND FOR BASEBALL FIELD BASES	-160.62
4/7/2026	CC SPORTS UNLIMITED, INC- BASEBALL FIELD BASES	2,837.62
4/8/2026	CC THE HOME DEPOT- NITEIZE GEAR TIE PROPACK- TENNIS COURTS	36.00
4/8/2026	CC IDENTOGO- FBI FEDERAL FINGERPRINTING CLEARANCE	25.95
4/10/2026	CC NETFLIX, INC- GENERAL EXP SENIOR BOOK CLUB	8.47
4/10/2026	CC KRAPP'S COACHES INC- TRANSPORTATION FOR SPRING NYC TRIP	2,578.00
4/13/2026	CC CUSTOM TATTOO- REMOVABLE TATTOOS FOR 67 GAMES	77.99
4/13/2026	CC AMAZON.COM- INFLATABLE CACTUS AND HORSE FOR SUMMER CAMP	68.04
4/14/2026	CC AMAZON.COM- YARD SALE SIGNS	98.59
4/14/2026	CC AMAZON.COM- NEON HEADBANDS FOR 67 GAMES	79.98
4/15/2026	CC AMAZON.COM- TENNIS COURT REPLACEMENT ROLLERS	129.90
4/15/2026	CC IN GSP SIGNS & BANNER- DECLARATION OF INDEPENDENCE POSTER SIZE FOR AMERICA 250	79.50
4/16/2026	CC AMAZON.COM- RUBBER END CAPS KIT FOR BOCCEE KIOSK	8.99
4/16/2026	CC AMAZON.COM- SOLAR LIGHTS FOR CAMP OUT; YARD GAMES, GLF PUTTING GAME SET, COWBOY HATS FOR SUMMER CAMP	398.69
4/16/2026	CC AMAZON.COM- SPY IN PENS AND WEIGHT BAGS FOR CANOPY FOR AMERICA 250	64.12
4/18/2026	CC AMAZON.COM- INFLATABLE CARNIVAL BUNDLE SPORTS GAMES FOR SUMMER CAMP	990.00
4/20/2026	CC AMAZON.COM- (2) KITS FOR BEAT BEN FUN RUN	27.58
4/21/2026	CC AMAZON.COM- STENCIL VINYL MASKING FILM FOR AMERICA 250	12.11
4/22/2026	CC AMAZON.COM- SUMMER CAMP SUPPLIES- (3) GOLF BUCKET GAME, GLUE, FABRIC; MONITOR STAND	246.33
4/22/2026	CC AMAZON.COM- CONSTRUCTION PAPER STORAGE FOR SUMMER CAMP	37.23
4/22/2026	CC AMAZON.COM- SKELETON KEY SET FOR BEAT BEN FUN RUN	42.66
4/23/2026	CC AMAZON.COM- INDOOR/OUTDOOR SPEAKER FOR SUMMER CAMP	239.00
4/24/2026	CC TARGET- RED BOWLS FOR BEAT BEN FUN RUM	21.18
		<b>\$8,329.06</b>

ASHLEY NOWAK		
3/27/2026	CC WF WAYFAIR- SALES TAX REFUND	-33.30
3/31/2026	CC PSATS- 2026 EDUCATIONAL CONFERENCE & EXHIBIT SHOW FOR M. MATTSON IN PW	199.00
4/6/2026	CC PRECISION GRAPHIX- CUSTOM NAME PLATES FOR BOARD ROOM	85.00
4/9/2026	CC COMM OF PA OB/OCO UNIFORM CONSTRUCTION- QTR 1 2026 UCC FEES	517.50
4/16/2026	CC FEDEX OFFICE- RETURN ADTRAN EQUIPMENT TO NET CARRIER	25.43
4/20/2026	CC THE PENN STATER HOTEL- HOTEL FOR D.BRADY TRAINNING	447.00
		1,240.63

KELLY BROPHY		
		49.99
4/16/2026	CC SUGARSYNC- 100 GB YEARLY 2026 PLAN SUBSCRIPTION- RCSTP	86.94
4/20/2026	CC HERHSEY LODGE RESTAURANT- FOR FOR D.GIEDER, K.KRAUSE. L. WERKHEISER, A.NOWAK AT PSATS	12.98
4/21/2026	CC HOTEL HERSHEY RESTAURANT- FOOD FOR D. GIEDER AT PSATS	80.01
4/21/2026	CC HOTEL HERSHEY RESTAURANT- FOOD FOR D. GIEDER, L. WERKHEISER, A. NOWAK AT PSATS	
		229.92
		<b>GRAND TOTAL</b>
		<b>22,030.42</b>

# MEMO

Date: May 28, 2026

From: Derek Davis, Township Manager

To: Board of Supervisors

Re: Presentation on the *Heart & Soul* program

---

In conjunction with the ongoing discussions regarding the anticipated comprehensive plan process, we have also been regularly discussing what I have been referring to as “planning-adjacent” topics.

The *Heart & Soul* program, guided by *PA Humanities*, is designed to be a long-term, strategic communication plan with the community. The thought process for East Goshen, as we have been discussing this, is that the program has potential to bring a value-added benefit to the comprehensive plan process if it lays a foundation of improved communication.

Jen Danifo, *Senior Manager of Programs* for *PA Humanities*, is here to discuss the programs and some of the details.

## **Draft Proposal: Pilot Composting Program for Food Scrap Diversion**

**Submitted to:** East Goshen Board of Supervisors

**Prepared by:** ESAC

**Date:** TBD

---

### **Executive Summary**

This proposal requests funding and approval to implement a six-month pilot composting program designed to divert residential food scraps from the municipal waste stream. The pilot will evaluate resident participation, waste diversion impact, and long-term feasibility of a township-supported composting initiative.

Organic waste represents a significant portion of residential trash and contributes to landfill volume and greenhouse gas emissions. A structured pilot program will allow East Goshen to assess whether a broader composting initiative is environmentally beneficial, financially viable, and supported by residents.

---

### **Background & Rationale**

Approximately 30% of residential waste consists of compostable materials such as food scraps and yard waste. When sent to landfills, these materials decompose anaerobically, producing methane—a potent greenhouse gas.

Composting provides multiple benefits:

- **Waste Reduction:** Diverts organic material from landfills
- **Environmental Impact:** Reduces methane emissions
- **Soil Health:** Produces nutrient-rich compost for landscaping and gardening
- **Water Conservation:** Improves soil moisture retention
- **Cost Savings:** Reduces landfill tipping fees and wastewater treatment burden

A recent community survey (70+ responses) indicates strong interest in composting options, with many residents currently relying on trash disposal or in-sink garbage disposals.

---

### **Current Waste Management Practices**

Survey responses indicate the following disposal habits:

- Trash disposal: 60%
- Garbage disposal units: 44%
- Composting (informal): 43%
- Private haulers: 4%

These findings highlight both opportunity and interest in a more structured composting solution.

**NOTE: Adds to more than 100 because you could select multiple choices**

---

## **Proposed Pilot Program**

### **Program Overview**

- **Duration:** 5 months (Aug–December)
- **Participants:** 50 households
- **Method:** Curbside collection of food scraps
- **Composting Contractor:** Back to Earth Composting

### **Program Goals**

- Measure volume of food waste diverted
  - Assess impact on household trash volume
  - Evaluate resident participation and consistency
  - Determine feasibility of long-term program expansion
- 

## **Pilot Program Details**

- Each participating household will receive:
    - One 5-gallon lidded collection bucket
    - Instructions on acceptable compost materials
  - Collection logistics:
    - Proposed Contractor currently picks up in East Goshen. Provided the best price for service.
    - Buckets placed curbside on designated days
    - Compost collected twice per month by a contracted composter
- 

## **Cost Analysis**

### **Pilot Program Costs**

- **Township Contribution:**  
50 households × \$10/month × 5 months = **\$2,500 total**
- **Resident Contribution:**  
\$10/month × 5 months = **\$50 per household**

### **Estimated Cost Avoidance**

- 50 households × 30 lbs/month × 5 months = **7,500 lbs (3.75 tons) diverted**
  - Landfill savings: **~\$337** (based on \$90/ton)
  - Additional savings expected in wastewater treatment due to reduced garbage disposal use
- 

## **Long-Term Considerations**

While curbside composting is effective for pilot evaluation, it may not be cost-efficient at scale. A more sustainable long-term model may include:

### **Drop-Off Composting Site**

- Centralized, secure compost collection location
- Capacity for ~100 households initially
- Scalable infrastructure

### **Estimated Costs (Year 1)**

- Setup: ~\$1,350 (shed, licensing, initial infrastructure)
- Monthly operations: ~\$608
- Total Year 1 Estimate: ~\$8,500

This model reduces per-household costs while maintaining diversion benefits.

---

## **Implementation Timeline**

- **Introduction to BOS** Jun 2
  - **Township Approval:** July 21 meeting
  - **Program Development & Communication (ready to go):** Jul21
  - **Participant Registration Opens:** Jul 22
  - **Bucket Distribution and Education:** late Jul- early Aug
  - **Program Launch (First Pickup):** Mid August
-

## Case Study Insights

Comparable municipalities have demonstrated:

- Diversion rates ranging from 6–30 lbs per household per month
- Participation rates from 1% to 23%
- Successful pilot programs leading to long-term adoption

These benchmarks suggest that pilot programs are an effective method to test and refine composting initiatives.

---

## Next Steps

- Finalize pilot program structure and funding approval
  - Establish billing and service agreements with composting provider
  - Launch participant registration and outreach campaign
  - Monitor and evaluate program performance
- 

## Funding Request

Approval is requested for:

- \$3,000 in Township funding to support the six-month pilot program
  - Authorization to proceed with implementation and vendor coordination
- 

## Conclusion

This pilot program represents a low-risk, data-driven opportunity to reduce waste, lower environmental impact, and respond to growing resident interest in sustainable practices. The results will inform future decisions on expanding composting services within the Township.

We respectfully request the Board of Supervisors approve funding and implementation of this pilot initiative.

---

# MEMO

Date: May 28, 2026

From: Derek Davis, Township Manager  
To: Board of Supervisors  
Re: 2026 Trash & Recycling Bid

---

The 2026 Trash & Recycling bid document is ready for approval after much input and discussions both internally and at a recent board meeting in April.

Some of the highlights in terms of the important items we are bidding out are as follows:

- Once a week pickup versus two days per week for trash (currently two days)
- Recycling will continue to be once a week
- We are asking for two bids for yard waste pickup (once a week versus every other week)
- Bulk trash options on the bid are once a week versus once a month

We are also going to do our best to ensure that the entire township can be picked up in one day (unlike now wherein the township is split in two and picked up on separate days) but will work that out directly with the bid winner.

There is a process we now need to go through in terms of advertising, meetings with potential bidders prior to the due date, question periods, and obviously giving vendors a chance to gather information so that they can put together an appropriate bid prior to an anticipated awarding by the board in the summer. Therefore, staff would appreciate board approval tonight after the questions and discussions are concluded.

**DRAFT MOTION:** Mr. Chair, I move we accept the 2026 Municipal Waste and Recycling bid for East Goshen Township as presented tonight and authorize the Township Manager to publicly advertise the bid and go through the bidding process.

**EAST GOSHEN TOWNSHIP  
MUNICIPAL BUILDING  
1580 PAOLI PIKE  
WEST CHESTER, PA 19380**

**SPECIFICATION MANUAL AND PROPOSAL FOR:  
MUNICIPAL WASTE AND RECYCLABLE MATERIALS COLLECTION**

Bidder Name: \_\_\_\_\_

Contact Person: \_\_\_\_\_

Address: \_\_\_\_\_  
\_\_\_\_\_

Phone: \_\_\_\_\_

Fax: \_\_\_\_\_

E-mail: \_\_\_\_\_



East Goshen Township  
1580 Paoli Pike  
West Chester, PA 19380  
E-mail: [info@eastgoshen.org](mailto:info@eastgoshen.org)

**ADVERTISEMENT** - The Board of Supervisors of East Goshen Township, Chester County, Pennsylvania is soliciting bids for the collection of municipal waste and recyclable materials in the Township. The Contract awarded will be for a three-year period with the option to extend the contract for two successive one-year periods.

Sealed proposals including one copy of the bid form and other documentation must be submitted to the East Goshen Township Director of Public Works, 1580 Paoli Pike, West Chester, PA, 19380, by no later than 10:00 AM on **July 9, 2026**, at which time the bids will be opened and read aloud.

Each proposal shall be accompanied by a certified check or bid bond in the amount of One Hundred Thousand Dollars (\$100,000.00). The successful bidder shall furnish a performance bond as required by Section 13.B of the East Goshen Township Municipal Waste and Recyclable Materials Collection Contract within fourteen (14) days of the contract award.

Bid specifications and proposal forms may be obtained from the East Goshen Township website, [www.eastgoshen.org](http://www.eastgoshen.org). See "RFPs and Bid Notices" under the "Services" tab.

Questions regarding this bid will be accepted in writing only at [info@eastgoshen.org](mailto:info@eastgoshen.org) and must be emailed by June 19, 2026, with the subject, "East Goshen Township Municipal Waste & Recycling Bid Question."

There will be a mandatory pre-bid conference for this contract on Tuesday, June 23, 2026, at 10:00 A.M. at the Township Municipal Building at 1580 Paoli Pike, West Chester, PA, 19380.

The Board of Supervisors of East Goshen Township reserves the right to waive technicalities, to reject any or all bids or items herein, and to make the award that is in the best interests of the Township.

Derek Davis  
Township Manager

Please publish June 3 and June 10, 2026.  
Please send proof of publication and invoice to:

Lynn Werkheiser  
[lwerkheiser@eastgoshen.org](mailto:lwerkheiser@eastgoshen.org)  
East Goshen Township  
1580 Paoli Pike  
West Chester, PA 19380



May 7, 2026

**EAST GOSHEN TOWNSHIP  
MUNICIPAL WASTE AND RECYCLABLE MATERIALS COLLECTION CONTRACT**

**1. INSTRUCTIONS TO BIDDERS:** The work to be performed shall consist of the collection of all "municipal waste" as defined by the Solid Waste Management Act, Act of July 7, 1980, P.L. 380, No. 97, 35 P.S. 6018.101 et seq. (hereinafter referred to as "Act 97"), from residences within the boundary of the Township of East Goshen Township, Chester County, Pennsylvania (hereinafter referred to as "Township"). The waste shall then be transported to the Lanchester Landfill for disposal, pursuant to the Chester County Designated Site Ordinance. **The Township will pay the tipping fee at the landfill. The term "tipping fee" includes any charges imposed by Lanchester Landfill for the disposal of Municipal Waste, Yard Waste, or Bulk Trash.** It is also the intent of the Township under this contract to continue an existing program of the collection of recyclable materials in accordance with the provisions of Section 304(c) of the Municipal Waste Planning, Recycling and Waste Reduction Act, Act of July 28, 1988, P.L. 556, No. 101, 53 P.S. 4000.304(c) (as amended) (hereinafter referred to as "Act 101").

**1.01 Invitation to Bid:**

In accordance with the Advertisement for Bids, sealed proposals are invited to be submitted for the performance of the work described herein.

The price(s) stated in the bid proposal shall cover all costs of any nature, incident to or growing out of the work including labor, material, equipment, transportation, and all else necessary to perform and complete the work in the manner and within the time specified in the Bid Specifications.

There will be a mandatory pre-bid conference for this contract on Tuesday, June 23, 2026, at 10:00 A.M. at the Township Municipal Building at 1580 Paoli Pike, West Chester, PA 19380.

**1.02 Receipt of Bids:**

Sealed proposals for performing the work described herein shall be received until 10:00 a.m. on July 9, 2026, at the Township Building, 1580 Paoli Pike, West Chester, PA 19380, at which time the bids will be opened and publicly read.

Bids received after the time specified for the public opening of bids will not be considered or accepted and will be returned unopened. It is intended that the award of the contract will be made by the Township or all bids rejected within sixty (60) calendar days from the date of opening the bids.

### 1.03 Copies of Contract Documents:

A full description of the work to be bid and of the requirements, provisions, and details thereof, is given in these Specifications dated May 7, 2026, copies of which may be obtained at: [www.eastgoshen.org](http://www.eastgoshen.org) (See "RFPs and Bid Notices" under the "Services" tab) or at the Township Building, 1580 Paoli Pike, West Chester, PA 19380.

### 1.04 Bid Security:

Each proposal shall be accompanied by a certified check from a bank or trust company satisfactory to the Township or bid bond from a surety company approved by Township and prepared on form enclosed, in the amount of five percent (5%) of the total bid amount a proposal guaranty to ensure the proper execution of the contract.

In the event any bidder shall, upon the award of the contract to it, fail to execute the contract or comply with the requirements hereinafter stated, the full amount of the proposal guaranty shall be forfeited to the Township as liquidated damages (not a penalty). The proposal guaranty of all bidders will be returned upon execution of the contract by the successful bidder.

### 1.05 Preparation of Proposals:

Proposals shall be submitted on the Bid Proposal Form furnished by the Township, properly filled out in ink or typed, and shall be duly executed by an authorized representative of the bidder. The bidder shall state in the proposal the price per unit of measure and lump sum price.

If the total price on any proposal is found to be incorrectly computed, the Township reserves the right to make such changes as are necessary in the extended amounts and total price on the basis of unit and lump sum prices given and the approximate quantities stated for the scheduled items therein.

### 1.06 Submitting Proposals:

All bids must be submitted on the Bid Proposal Form furnished by the Township. The proposal, together with the proposal guaranty, shall be enclosed in an opaque sealed envelope, bearing on the outside the name, address, **and email** of the bidder, "East Goshen Township Municipal Waste & Recyclables Contract," and the date and time of bid opening. Proposals will be accepted at the place and until the time stated herein and in the Advertisement for Bids.

If forwarded by mail, the sealed envelope shall be inserted in another envelope addressed to East Goshen Township, 1580 Paoli Pike, West Chester, PA 19380. Mailed proposals must be received by the Township prior to the time set for opening bids if they are to be considered, and the Township will not be responsible for any delays caused by mailing.

Any proposals received after the time set for the public receipt of bids will not be considered or accepted and will be returned unopened.

1.07 Qualifications of Bidders:

The Bidder's experience, necessary facilities, and financial resources to perform the work will be examined by the Township and the Township reserves the right to reject the proposal of any Bidder not possessing satisfactory qualifications as determined in the Township's sole discretion.

1.08 Surety:

The name and address of each surety furnishing the Contractor's bid bond as required hereinafter must be stated in the proposal, and the surety's consent must be given in the form attached thereto.

In addition, each surety's consent must be accompanied by a power of attorney nominating, constituting, and appointing the person whose signature appears on said surety's consent as the true and lawful agent of the surety to execute all bonds and the consent on its behalf.

In case the surety named in the proposal is not approved by the Township, the bidder will be required, within five (5) days or such further period as may be prescribed by the Township after notice of such disapproval, to substitute the name of another surety satisfactory to the Township.

1.09 Addenda:

Any revision or interpretation of the Contract Documents prior to bid opening will be made in the form of an Addendum, duly issued and a copy of such Addendum will be posted on the East Goshen Township website, [www.eastgoshen.org](http://www.eastgoshen.org) (See "RFP and Bid Notices" under the "Services" tab) and emailed to each person receiving a set of the Contract Documents. The Township will not be responsible for any other explanations or interpretations of the Contract Documents or any part thereof. Each bidder shall be responsible for reviewing the East Goshen Township Website for Addendum as they are posted.

1.10 Withdrawal of Bids:

A proposal, after having been submitted, may be withdrawn by the bidder prior to the time set for the opening of bids upon the presentation of a written request for such withdrawal to the Township Secretary.

#### 1.11 Right to Reject Bids:

The Township will determine who is the lowest responsible bidder on the basis of the bids submitted and reserves the right to reject any or all bids and re-advertise if the best interest of the Township will thereby be promoted. The Township reserves the right to waive technical defects of any nature, if in its judgment, the interest of the Township shall so require.

No proposal will be considered from any person, firm, or corporation who has defaulted in the performance of any contract or agreement made with East Goshen Township.

The Township reserves the right to waive any informalities in the bids received, to award the contract only to a bidder whose proposal is deemed by the Township to be most advantageous to the public interest, and to reject any or all bids for any reason whatsoever in the Township's sole and absolute discretion.

Proposals that are deemed by the Township to be incomplete, conditional, or obscure, or which contain additions, erasures, alterations, omissions, or irregularities of any kind may be rejected as unresponsive.

#### 1.12 Sales and Use Tax Acts:

Bidders must make their own independent analysis of Pennsylvania sales and use taxes and the applicability or non-applicability thereof to the services to be provided and performed under and as part of the work. All taxes are to be included in the unit prices bid and the Township will not make any separate payments of taxes.

#### 1.13 Award of Contract:

It is intended that the award of the contract will be made by the Township or all bids rejected within sixty (60) calendar days from the date of opening the bids. If identical low responsible bids are received, then the award will be decided by the single tossing of a coin. The low bidders will be notified of date, time, and place of the toss, should it be required, so that they may be present if desired.

#### 1.14 Execution of Contract and Bond:

The bidder, whose proposal is accepted, shall be required, within fourteen (14) days after receipt of notice of the award of the bid, to deliver to the Township the Contract in the form provided duly executed and its execution duly proved, and at the same time, deliver to the Township all bonds and other documents required in the specifications.

## **2. DEFINITIONS:**

**Bulk Trash Items:** A bulk trash item is a single large item of a weight and construction such that two people can lift it. The definition includes, but is not limited to, items such as water heaters, stoves, ranges, washers, dryers, refrigerators, freezers, dishwashers, air conditioners, sofas, mattresses, box springs, bureaus, tables, chairs, and other items from residences having at least one dimension of 24 inches (24") or more. The term includes White Goods as defined below.

The Contractor shall not be required to collect or transport any item that contains or once contained Freon unless a certificate accompanies the item that attests that the Freon was removed and recycled in accordance with applicable state and/or federal laws.

The Contractor is not required to collect or transport electronic devices regulated by the Covered Device Recycling Act (Act 108) of 2010.

**Building Materials:** Includes such materials as drywall, insulation, tile, windows, sinks, bathtubs, toilets, doors, flooring, drywall, deck boards, lumber, cabinets, doors, shingles, block, brick, pieces of concrete or other debris that would typically result from a remodeling project or the construction of an addition, deck, garage, shed, or other debris that would result from the demolition of a house, shed, above ground pool, swing set, deck, or fence.

**Contractor:** The person, partnership, company, firm or corporation that is awarded the contract for collection of Municipal Waste, Yard Waste, Recyclable Materials, and Bulk Trash in East Goshen Township.

**Materials and Recovery Facility (MRF):** A specialized plant that receives, separates, and prepares recyclable materials such as paper, plastics, glass, and metals for marketing to end-user manufacturers. The Township has entered into an agreement with Chester County to utilize the County's current Materials and Recovery Facility contract holder for processing of recyclable materials. Total Recycle, Inc. currently has the contract with the County and their facility is located at 1270 Lincoln Road, Birdsboro, PA, 19508.

**Municipal Waste:** Any garbage, refuse, industrial lunchroom or office waste and other material, including solid, liquid, semi-solid or contained gaseous material, resulting from operation of residential, municipal, commercial, or institutional establishments, and from community activities, and any sludge not meeting the definition of residual or hazardous waste in Act 97 from a municipal, commercial, or institutional water supply treatment plant, wastewater treatment plant, or air pollution control facility.

The term includes small appliances and furniture whose longest dimension is less than 24 inches (24”).

The Contractor shall not be required to collect or transport any item that contains or once contained Freon unless a certificate accompanies the item that attests that the Freon was removed and recycled in accordance with applicable state and/or federal laws.

The Contractor is not required to collect or transport electronic devices regulated by the Covered Device Recycling Act (Act 108) of 2010.

The term does not include Recyclable Materials, Building Materials, Construction Debris, full or partially full paint cans, used motor oil, batteries, automotive parts and tires, rocks, dirt, and branches over 6” in diameter.

Ordinance: The East Goshen Township Municipal Waste Collection and Residential Recycling Ordinance, as codified in Chapter 194 in the Code of the Township of East Goshen.

Township: East Goshen Township, Chester County, a Township of the Second Class located within the Commonwealth of Pennsylvania.

Recyclables: Includes paper, cardboard, metal, glass, and plastics, as described in detail on the attachment titled, “Total Recycle, Inc. Recycling List.”

Single-Family Dwelling Unit: A single-family structure on its own lot that has a yard on four sides or a semi-detached family structure that has a yard on three sides. A semi-detached unit is commonly known as a twin or double. The term also includes the 15 townhouses in Dutts Mill.

White Goods: Includes, but is not limited to, such items as water heaters, stoves, ranges, cooktops, washers, dryers, refrigerators, freezers, dishwashers, air conditioners, and similar appliances.

Yard Waste: Includes weeds, brush, grass clippings, sticks, twigs, branches six inches (6”) or less in diameter, and other material that is typically generated from the yard and garden of a single-family dwelling unit. The term includes leaf waste and Christmas trees. The term does not include dirt, stones, or branches over six inches (6”) inches in diameter.

### **3. SCOPE OF WORK**

#### **A. EQUIPMENT:**

1. Types of Vehicles: All trucks shall be specifically designed to prevent leakage of any liquids or fluids. All open-type vehicles shall be equipped with suitable covering to prevent the discharge of refuse from the vehicle.
2. Conditions and Appearance of Vehicles: All vehicles and equipment shall be maintained in good working and operating condition, both with respect to safety and sanitation. Equipment shall not be overloaded so that refuse may spill or drop on the highways or maintained as to permit the leakage of fluids. All trucks shall be regularly cleaned and kept in proper condition. Trucks and equipment shall likewise be of a uniform color and shall bear the name and address of the Contractor plainly visible on both cab doors.
3. Each truck shall have at least one broom and one shovel to clean up refuse that may be spilled or otherwise scattered during the process of collection. The disposal of these materials is the responsibility and at the expense of the Contractor.
4. List of Equipment: The Contractor shall file with the Township Manager a list of all vehicles and equipment with identification information thereon. Changes in equipment shall be promptly reported to the Township Manager so that records will be correct and accurate at all times.
5. Storage of Equipment: The Contractor, at its expense, shall store and park its equipment at a convenient and lawful place. No trucks or equipment may be parked or stored on Township streets except during collection periods.
6. The Contractor shall ensure that hydraulic fluid spilled from any Contractor collection vehicle shall be immediately cleaned from any street or road in the Township.
7. All equipment utilized by the Contractors must be five years old or newer.

**B. EXAMINATION OF TOWNSHIP:** Bidders shall inspect the Township so that they can make their own judgment concerning all circumstances affecting the cost of service in question and the nature of the work to be performed. Bidders shall assume all risks, whether or not patent, latent, known, hidden, or foreseeable.

**C. SPECIFICATIONS AND DOCUMENTS:** Bidders are advised to examine carefully the specifications and all documents describing the proposed work and to make their own independent judgment with respect to the circumstances affecting the cost of work and the performance required by said documents.

- D. CONTRACTOR PHOTOGRAPH EQUIPMENT:** The trucks used by the Contractor for the collection of Municipal Waste, Recyclables, Yard Waste, and Bulk Trash shall be equipped with cameras and have the equipment necessary to transmit photos. In order to address complaints about missed collections, the Contractor shall take a date and time stamped photo of any residence that does not have Municipal Waste, Recyclables, Yard Waste, and/or Bulk Trash out for collection. In addition, the Contractor shall take a date and time stamped photo of any residence that has placed out any Municipal Waste, Recyclables, Yard Waste, and/or Bulk Trash out for collection that is not in compliance with the requirements set forth in these bid documents. The Contractor shall retain these photos for a period of 72 hours. The Contractor shall have the capability to transmit a photo(s) for a specific location to the Township via email or text message within 10 minutes of the request.
- E. SINGLE-FAMILY DWELLING UNITS:** The Contractor will be required to submit its bid based upon the number single-family dwelling units listed on the Cost Breakdown form. Payment will be based upon the actual number of single-family dwelling units from which Municipal Waste and Recyclable Materials are collected during a given month.

The Contractor understands that during the term of the contract, the Contractor may be required to increase or decrease the number of single-family dwelling units that are serviced at the same monthly cost per single-family dwelling unit that was submitted by the Contractor on the Proposal Form.

- F. COLLECTION AND DISPOSAL:** The Contractor shall supply all of the labor and equipment required to collect from the Single-Family Dwelling units in the Township all Municipal Waste, Yard Waste, and Bulk Trash items, and transport the same to the Lanchester Landfill; and to collect all Recyclable Materials from the Single-Family Dwelling units in the Township and transport same to the County-appointed Materials Recovery Facility. The Contractor shall be able to process and market the recyclable materials in the event the appointed MRF is not operational.

The Contractor shall comply with the Ordinance, all applicable laws and statutes of the Commonwealth of Pennsylvania, including but not limited to Act 97 and Act 101 and all applicable regulations promulgated there under, of the County of Chester and of the United States Government and/or their agencies with respect to Worker's Compensation and the hauling and disposal of all materials collected.

Collection shall be made regardless of weather conditions, unless authorization is received by the Township. Authorization may be verbal, but will be followed in writing within one business day. The Contractor will make the collections scheduled for the day missed due to weather conditions within the next day.

THE RULES AND REGULATIONS PERTAINING TO THE COLLECTION AND DISPOSAL OF MUNICIPAL WASTE AND RECYCLABLE MATERIALS ISSUED BY TOWNSHIP, COUNTY, STATE OR FEDERAL AGENCIES SHALL BE CONSIDERED TO BE AN INTEGRAL PART OF THESE REGULATIONS AND SHALL BE BINDING ON THE CONTRACTOR.

## **G. TOWNSHIP RESPONSIBILITIES:**

### **1. Preparation of Municipal Waste, Yard Waste, and Bulk Trash items:**

a) Municipal Waste - Shall be placed at the curbside on the designated collection days. The waste shall be placed in trash bags that will be taken with the waste or in a trash container that will be emptied by the Contractor. The weight of each trash bag or trash container shall not exceed fifty (50) pounds. Lightweight materials shall be properly tied into bundles or packaged in a manner designed to prevent any scattering while the Contractor is handling the same or while such materials await collection. Bundles shall be of a size and construction to permit handling by one man and shall not exceed fifty (50) pounds in weight.

b) Yard Waste shall be placed at the curbside on the designated collection days. The waste shall be placed in biodegradable paper bags that will be taken with the waste or in a trash container that will be emptied by the Contractor. The weight of each paper bag or trash/yard waste container shall not exceed fifty (50) pounds. Yard waste that is too bulky to be placed in a trash container shall be cut up and tied into bundles. The bundle(s) shall be of such size that the longest dimension thereof shall not exceed three (4') feet, and the total weight of each bundle shall not exceed fifty (50) pounds. Yard waste in plastic bags will not be collected. Branches over six inches (6") in diameter will not be collected.

1) Christmas trees shall be placed at the curbside on the designated Yard Waste collection days. Christmas trees in plastic bags will not be collected. Christmas trees over 6 ft tall must be cut into 3-ft or 4-ft (or shorter) lengths.

c) Bulk Trash items include White Goods and shall be placed at the curbside on the designated collection days. The Contractor is not required to collect or transport any item that contains or once contained Freon unless a certificate accompanies the item that attests that the Freon was removed and recycled in accordance with applicable state and/or federal laws.

### **2. Designation and Preparation of Recyclable Materials:**

a) Recycling containers shall be placed at the curbside on the designated recycling day. The recycling containers shall be those supplied by the Township or similar containers that have been purchased by the residents. The Township has provided the residents with 16-gallon open bins and/or 65-gallon toters with lids. The total weight of any container shall not exceed fifty (50) pounds.

3. Storage of Recyclable Materials: The Township will not provide storage for the Recyclable Materials.

4. Program Monitoring and Receipt of Citizen Complaints: The Township shall monitor the Contractor's performance and shall take citizen complaints. The Township will notify Contractor of these complaints.

5. Violation Notices: The Township will supply the Contractor with violation notices. The Contractor will be responsible for tagging uncollected items and marking the violation notice with the reason items were not collected.

6. Notification: The Township has the ability to advise residents in the event collections will be or have been canceled due to weather conditions or some other emergency.

**H. CONTRACTOR RESPONSIBILITIES:** The Contractor shall abide by all traffic regulations while collecting the Municipal Waste, Recyclable Materials, Yard Waste, and Bulk Trash. In addition, the Contractor shall comply with all applicable Federal, State, County, and Township regulations.

1. Municipal Waste: The Contractor shall provide all labor and equipment necessary to collect Municipal Waste from the single-family dwelling units in the Township and transport the same to the Lanchester Landfill. The total weight of each container shall not exceed fifty (50) pounds.

2. Recyclable Materials: The Contractor shall provide all labor and equipment necessary to collect recyclable materials from the single-family dwellings in the Township and transport same to the designated Materials Recovery Facility (MRF). The total weight of each container shall not exceed fifty (50) pounds.

- a. The Contractor shall not contaminate the collected Recyclable Materials with non-recyclable materials.
- b. The Contractor shall be required to collect all properly prepared Recyclable Materials but shall not be required to collect improperly prepared Recyclable Materials.
- c. The Contractor shall tag recycling containers that do not contain properly prepared Recyclable Materials or contain Municipal Waste with a violation notice supplied by the Township.
- d. NOTE: The Township reserves the right to change the designated Recyclable Materials list.

3. Bulk Trash Items: The Contractor shall provide all labor and equipment necessary to collect Bulk Trash items and waste from the Single-Family Dwelling units in the Township and transport the same to the Lanchester Landfill.

a. White Goods Items: The Contractor shall provide all labor and equipment necessary to collect White Goods from the Single-Family Dwelling units in the Township and transport the same to a scrap metal facility. The Contractor is not required to collect or transport any item that contains or once contained Freon unless a certificate accompanies the item that attests that the Freon was removed and recycled in accordance with applicable state and/or federal law. The Township will pay all fees imposed by the scrap metal facility for disposal of said White Good items and receive any revenues generated from the scrap metal facility. The scrap metal facility shall be approved by the Township; however, the approval shall not be unreasonably withheld.

4. Yard Waste: The Contractor shall provide all labor and equipment necessary to collect Yard Waste from all of the Single-Family Dwellings in the Township and transport the same to the Lanchester Landfill.

a. All Yard Waste shall be placed in a biodegradable paper bags that will be taken with the Yard Waste or in a trash container that will be emptied by the Contractor. Yard Waste shall not be placed in plastic bags. When applicable, Yard Waste shall be securely tied into a bundle and shall be of such size that the longest dimension thereof shall not exceed FOUR (4') feet, and the total weight thereof shall not exceed fifty (50) pounds. Branches over six inches (6") in diameter will not be collected. There is no limit on the amount of Yard Waste that can be placed out for collection.

I. **PROCESSING AND MARKETING OF RECYCLABLE MATERIALS**: The Township has entered into an agreement with Chester County to utilize the Materials Recovery Facility designated by the County Processing and Marketing contract for the processing of Recyclable Materials. Total Recycle, Inc. currently has the contract with the County and their facility is located at 1270 Lincoln Road, Birdsboro, PA, 19508.

a. In the event the County's contract with Total Recycle, Inc. is not renewed, but the County enters into an agreement with another firm to process and market the Recyclable Materials, the Contractor shall deliver the materials to that firm's facility.

b. The price per ton paid to the Township or negative charge per ton paid by the Township to process and market the recyclable materials shall be in accordance with the prices quoted in "Recycling Times" or some other trade journal. It is expected that the prices for these recyclable materials may fluctuate during the term of this contract.

- c. The Township will pay all fees imposed by the Materials Recovery Facility (MRF) holding the County Processing and Marketing contract for disposal of said Recyclables and receive any revenues generated from that MRF for the sale of said Recyclables.

**J. SUMMARY OF COLLECTIONS:**

- 1. **Residential Collections:** The Contractor will be required to provide the following services at each single-family dwelling unit:
  - a. Municipal Waste Collection: Based on Awarded Option. See Section K - Schedule of Collections.
  - b. Single-stream (co-mingled) Recyclables shall be collected once a week.
  - c. Yard Waste: Based on Awarded Option. See Section K – Schedule of Collections.
  - d. Bulk Trash: Based on Awarded Option. See Section K - Schedule of Collections
  - e. For bidders' reference, below is a summary of the tonnage of MSW, Recyclable Materials and Yard Waste collected in East Goshen Township in 2024 and 2025:

Month	MSW	Recyclables	Yard Waste
January	281.87	101.59	56.95
February	237.04	68.39	40.94
March	252.57	70.76	48.76
April	319.36	79.17	29.06
May	174.84	71.85	23.04
June	297.53	85.86	69.84
July	314.07	86.91	53.33
August	273.78	77.61	53.96
September	346.12	81.89	36.80
October	282.74	84.97	29.70
November	324.44	105.23	100.78
December	362.67	123.78	42.34
Totals	3467.03	1038.01	585.50

Month	MSW	Recyclables	Yard Waste
January	264.01	77.33	18.79
February	228.01	67.13	18.26
March	275.98	76.09	65.31
April	288.17	83.01	94.69
May	315.99	77.94	58.23
June	296.15	86.44	59.90
July	277.24	81.68	76.61
August	264.71	67.62	66.71
September	299.85	82.12	48.60
October	253.15	72.30	73.92
November	259.72	70.10	154.14
December	308.82	114.45	43.83
Totals	3331.80	956.21	778.99

- 2. **Township Facilities:** The Contractor will be required to provide the following services at the Township Building, 1580 Paoli Pk:
  - a. One three-yard Contractor-provided Municipal Waste dumpster to be serviced weekly
  - b. Two to three 96-gallon Township-provided recycling totes to be serviced weekly
  - c. 30-yard roll-off Contractor-provided Municipal Waste dumpster to be serviced as needed

3. The Contractor will be required to provide the following service at the Township Park, 1661 Paoli Pk:
  - a. Two three-yard Contractor-provided Municipal Waste dumpsters to be serviced weekly
  
4. The Contractor will be required to provide the following services at Ridley Creek Sewer Treatment Plant, 1751 Towne Dr:
  - a. One three-yard Contractor-provided Municipal Waste dumpster to be serviced weekly
  - b. Transport the Township-owned 20-yard sludge dumpster located at the Ridley Creek Sewer Treatment Plant, 1751 Towne Dr, West Chester, PA 19380 to the Lanchester Landfill to be emptied, and then returned to its original location with a Contractor-provided liner. Hauling shall be done on an as-needed basis.

**K. SCHEDULE OF COLLECTIONS: THE CONTRACTOR SHALL BE REQUIRED TO COMMENCE COLLECTION SERVICES ON JANUARY 1, 2027**

**1) Single-Family Dwelling Schedule for Municipal Waste, Recyclables, Yard Waste, and Bulk Trash Collection:** The Contractor shall manually collect all Municipal Solid Waste, commingled Recyclable Materials, Yard Waste, and Bulk Trash placed at curbside from all Single-Family Dwelling units in the Township on days specified. We are soliciting bids for two different schedule options:

**a) Municipal Waste**

- Residents to provide trash containers or trash bags
- Pickup days to be negotiated with bid winner
- We are requesting pricing on two pickup frequency options. **Bidders must supply a price for both options for bid to be considered.**
  - i. Option 1: One pickup per week
  - ii. Option 2: Two pickups per week

**b) Recyclable Materials**

- Township will provide 65-gallon recycling containers
- Pickup day to be negotiated with bid winner
- We are requesting pricing on one frequency option:
  - i. One pickup per week

**c) Yard Waste**

- Residents may place yard waste in paper bags or in totes
- Pickup day to be negotiated with Contractor
- We are requesting pricing on two pickup frequency options. **Bidders must supply a price for both options for bid to be considered.**

- i. Option 1: One pickup per week
- ii. Option 2: Biweekly pickups (one pickup every other week)

**d) Bulk Trash**

- Two items max
- Pickup day to be negotiated with bid winner
- We are requesting pricing on two pickup frequency options. Bidders must supply a price for both options for bid to be considered.
  - i. Option 1: One pickup per week
  - ii. Option 2: One pickup per month

**2) Township Facilities Schedule – see Summary of Collections, Sections J.2, J.3, & J.4**

**L. COLLECTION HOURS**

Collection of Municipal Waste shall be made between the hours of 6:00 a.m. and 6:00 p.m. All Municipal Waste and Recyclable Materials shall be picked up such that the latest collection is able to make delivery to the Municipality's designated processing facility before it closes.

**M. HOLIDAYS**

"Holidays" shall mean the holidays the Lanchester Landfill observes. If any scheduled pickup falls on a holiday observed by the Lanchester Landfill, it will be collected the next day. All pickups in the same week following that Holiday will also be delayed by one day, so that the same amount of pickups occur in weeks with Holidays as in weeks without Holidays.

**N. INCLEMENT WEATHER**

Collection shall be made regardless of weather conditions, unless authorization is received from the Township. The Township must be notified of the request for authorization by 12:00 P.M. prior to cancellation. Authorization may be verbal but will be followed in writing within one business day. The Contractor will make the collections scheduled for the day missed due to weather conditions on the next scheduled pickup day. All pickups in the same week following that inclement weather day will also be delayed by one day, so that the same amount of pickups occur in weeks with inclement weather as in weeks without inclement weather.

**O. UNCOMPLETED ROUTES**

If the Contractor is unable to complete a route for any reason, the Contractor must let the township know by 3:00pm on the scheduled day. The uncompleted pickups must be collected the next day. The Contractor must provide written explanation for the interruption and rescheduling information to be communicated to residents.

**P. RECORD KEEPING:** The Contractor shall provide the Township with the tonnage of Municipal Waste and Bulk Trash (excluding White Goods) collected, the Tonnage of White Goods collected, the tonnage of Recyclable Materials collected, and the tonnage of Yard Waste collected on a monthly basis. The Contractor shall provide to the Township by the 15<sup>th</sup> of each month, Certified Weight Slips for all Municipal Waste disposed of in the previous month.

**Q. DISPOSITION OF WASTE, TIPPING FEES:** All Municipal Waste, Yard Waste, and Bulk Trash items (excluding White Goods) contracted to be collected herein shall be delivered to the Chester County Solid Waste Authority Lanchester Landfill. The Township shall pay the tipping fee. The term "tipping fee" includes any charges imposed by Lanchester Landfill for the disposal of Municipal Waste, Yard Waste, or Bulk Trash.

**R. NEW SINGLE-FAMILY DWELLING:** The Township will notify the Contractor of new Single-Family Dwellings. The Contractor shall begin collection services for those Single-Family Dwellings on the next regularly scheduled collection day.

**S. MAJOR ROADS:** In order to minimize delays for motorists, the Contractor shall not collect Municipal Waste, Recyclables, Yard Waste, or Bulk Trash items during peak traffic times (7:00 AM to 9:00 AM and after 4:30 PM) for single-family dwelling on: North Chester Road, Boot Road, and Paoli Pike.

**T. COMPLAINTS AND SUPERVISION:**

- 1) If awarded the contract, the Contractor shall provide a responsible manager who shall be available to Township staff and residents and may be contacted at a local telephone number and email during each working day between the hours of 6:00 a.m. and 6:00 p.m. to receive complaints, assist with any problems, answer inquiries, and resolve disputes with respect to services to be supplied pursuant to the Contract.
- 2) The Contractor shall have a supervisor with pickup truck in the Township during any day that Municipal Waste, Recyclable Materials, Yard Waste, and Bulk Trash items are to be collected. The supervisor shall have a cell phone so that they can be in direct contact with the Township in order to remedy any missed collections, or any other problems that occur during the course of collections. The supervisor shall arrive at the Township no later than noon and shall not leave the Township until 6:00 PM or the completion of collections, whichever is later.

**U. CONDUCT OF CONTRACTOR'S EMPLOYEES:** The Contractor shall be held responsible for the conduct and deportment of the Contractor's employees during the performance of their work. Said employees shall not use loud, abusive, profane, or lewd language in their dealings with the public, nor shall they use loud, abusive, profane, or lewd language amongst themselves during the performance of their work. Further, said employees shall conduct their work as quietly as possible with a minimum of interference to pedestrian and vehicular passageway through the Township.

1) Offensive Employees:

The Contractor is expected to hire competent employees to carry out the requirements of the contract. The Contractor shall appropriately discipline any employee for:

- a. Intoxication
- b. Using loud, profane, vulgar, or obscene language
- c. Soliciting gratuities or tips from the public for services to be performed hereunder
- d. Refusing to collect or handle refuse as herein required and defined
- e. Wanton or malicious damage or destruction of containers or receptacles
- f. Wanton or malicious scattering or spilling refuse
- g. Any other wanton, willful, or reckless disregard of safety or sanitary requirements
- h. Any act which may constitute a public nuisance or disorderly conduct
- i. Verbal or physical altercations with other Contractor employees or Township residents and Township staff are strictly prohibited.

2) Care of Trash Cans and Recycling Containers: The Contractor's employees shall handle all trash containers and recycling containers with reasonable care to avoid damage. **The Contractor shall place each empty container back in its original location after emptying.** Each collection crew shall have a broom and shovel, and they shall promptly clean up any materials spilled during collection.

#### **4. VIOLATIONS, REJECTED LOADS, AND TERMINATION OF CONTRACT**

A. Violations: It is understood that the orderly and proper collection of Municipal Waste, Recyclable Materials, Yard Waste, and Bulk Trash as defined herein, is a matter of serious and vital concern to the Township because of the effect which it has upon the health and welfare of the residents. Furthermore, it is anticipated that occasional minor breaches or violations may occur during the course of the performance of the contract. In the case of minor breaches or violations, the Township Manager may, on behalf of the Township, invoke the stipulated liquidated damages listed below. This

determination and certification of the same shall be final.

The Township Manager or their designee shall notify the Contractor of such violations. If the violation is not corrected within 24 hours, the Township Manager may assess a fine in accordance with the following schedule of liquidated damages:

1. The collection of Municipal Waste from non-East Goshen Township dwelling unit or business establishment and hauling same to the landfill - \$500.00 per offense
2. Failure to collect Municipal Waste, Yard Waste, Bulk Trash, or Recyclables - \$50.00 per address, per occurrence.
3. Failure to replace the trash can(s) or recycling container(s) in original location - \$25.00 per occurrence. The Township is aware that wind and large trucks can move refuse and recycling containers after they have been emptied, and allowances will be made for windy days and for properties located on major roads.
4. Failure of a truck and crew to finish a regular route - \$500.00 per day; per route.
5. Using or maintaining trucks in a leaking or unsanitary condition - \$300.00 per offense.
6. Damaging or carrying away a resident's Municipal Waste or Recyclables container(s) – replacement cost of the container.
7. Failure to clean up any waste materials or Recyclables that fall to the ground - \$300.00 per offense.
8. Failure to have a supervisor in the Township as required by Section T of the Scope of Work - \$300.00 per offense.

Any damages assessed for any of the aforesaid violations shall be deducted from the next payment due to the Contractor.

B. Loads Rejected by the Recycling Center: The Contractor is responsible for collection of only properly prepared Recyclables. If any load of recyclable materials is rejected at the recycling center because of contamination, the Contractor will pay the Township

the revenues that the Township would have received if the load had not been contaminated. In addition, the Contractor shall assume all costs associated with the disposal of the rejected load.

C. Contractor Default and Notice: The following events shall constitute an event of default (“Event of Default”):

1. The failure of the Contractor to collect the materials required herein for a period of five (5) consecutive days; or
2. Five or more violations by the Contractor as set forth in Section 4.A within a one (1) week period for two (2) consecutive calendar weeks.

The Township shall not proceed against the Contractor under Section 4.C unless notice describing the Event of Default has been provided to the Contractor. The Contractor shall be given a 24-hour period to cure such Event of Default before the Township exercises one of the remedies provided in Section 4.D.

D. Township’s Remedies upon Event of Default: In the Event of Default, the Township may exercise any one or more of the following remedies:

1. Terminate the Contract by providing written notice to Contractor; and/or
2. Notifying the Contractor’s surety and collecting on the performance bond that Contractor has posted with the Township; and/or
3. File an action in law against the Contractor seeking payment of all damages sustained by the Township as a result of Contractor’s default; and/or
4. File an action in equity against Contractor seeking specific performance of the Contractor’s obligations under this Contract.

The Township shall, in addition, have such other legal remedies for the collection of such obligations as they are now, or may hereafter be provided by law. All remedies of the Township shall be cumulative and not exclusive and are enforceable in the Township’s discretion alternatively, successively, or concurrently on any one or more occasions and in any order the Township may determine.

E. Force majeure: It is hereby stipulated and agreed that in the event of a labor stoppage; labor strike, lockout; destruction of or damage to the Contractor’s equipment caused by Acts of God; fires; explosions or other matters beyond the reasonable control of the Contractor; restraints of government; lawful orders of the court, administrative agencies or governmental officers; suspension, termination or interruption of governmental licenses or permits; changes in laws, regulations, or ordinances; the Contractor shall not be considered in default or breach of the Contract by reasons thereof, provided, however, that the Township’s cost of performing the work specified in the Contract during such

period shall be charged to and reimbursed by the Contractor as in the case of default by the Contractor.

**5. BIDDER'S QUALIFICATIONS AND EXPERIENCE:** Bidders submitting proposals must have previous experience in the collection of Recyclable Materials and Municipal Solid Waste. **Bidders shall submit the following with their proposal:**

**A. Financial:**

- 1) Bidders submitting proposals must possess all of the following mandatory qualifications:
  - a) The bidder must be a financially secure company or corporation. Bidders shall submit the following with their bid:
    - Annual reports or audited financial statements (or income statement and balance sheet) for the past three (3) years.
    - Identification of any and all legal actions or proceedings where the bidder was named a defendant within the last five (5) years which involved a municipal waste and recyclables contract.

**B. Experience:**

- 1) The bidder must have previous experience in the collection of Recyclables and Municipal Solid Waste. Bidders shall submit the following with their bid:
  - Locations of curbside programs for which the bidder collects Recyclables
  - Number of households collected and/or volumes collected, and frequency of collection for listed recycling programs
  - Materials collected by bidder
  - Ownership and description of collection vehicles, including make, model, and year
  - A list of locations in Pennsylvania where the bidder is under contract to collect Municipal Solid Waste and/or Recyclable Materials with references for listed locations. References to include the name of the municipality and the name, address, email, and telephone number of the contact person.

- References for other municipal clients served by bidder in the past three years. References to include name, position, location of program, address, email, and telephone number.

**6. TERM OF CONTRACT:**

The contract awarded hereunder shall be for three (3) consecutive years commencing on January 1, 2027, and ending on December 31, 2029; with the Township having the option to renew the contract for two (2) successive one-year periods, which option shall be exercised by the Township no later than ninety (90) days before the annual expiration date of the Municipal Waste and Recyclable Materials Collection Contract.

The Board of Supervisors, in its sole discretion, shall have the option to extend the contract for two additional one-year periods. The Board of Supervisors shall notify the Contractor of their decision to extend or not extend the contract a minimum of 90 days before the expiration date of the then current term of the contract.

If the contract is extended, all costs will be increased by a percentage equal to the change in Consumer Price Index US City Average for All Urban Consumers (CPI-U) for the twelve-month periods ending in December 2027, 2028, 2029, and 2030, as applicable.

**7. ASSIGNMENT:** It is understood and agreed by the Contractor that, during the performance of its duties under this contract, it will not assign its contractual rights or its duties and obligations arising hereunder, to any third person without the prior written approval of the Township being first had and obtained, which approval the Township shall be under no obligation to give, it being at all times understood that the Contractor is not acting as an agent or a subsidiary of any other entity.

**8. MERGER/BANKRUPTCY/BULK SALE:** During the term of the contract, Contractor covenants, warrants and agrees that it will not file any proceeding in bankruptcy or reorganization under the bankruptcy laws of the United States or under any specific debtor, receivership, composition for creditors, liquidation proceedings or similar proceedings under Pennsylvania law.

Contractor further covenants, warrants, and agrees that, during the term of any contract awarded, that it will not merge with any other entity or become a subsidiary of any other person, corporation, or any other entity. Contractor also warrants that it will not undertake the sale of its assets, stock, or equipment during the term of the contract in any fashion, which might jeopardize or compromise service or performance.

If, despite the covenant contained herein, said Contractor does file proceedings in bankruptcy or like proceedings in State courts, or by merger or sale becomes acquired by any other corporation or entity, such actions shall constitute a termination of the contract and a forfeiture of the

Performance Bond, at the Township's sole election.

**9. INSPECTION:** The Township or any authorized representative thereof may inspect the collection process employed by the successful Contractor under the contract and may require the correction of any improper or deficient performance of the contract through the designated supervisor of the Contractor. The Township specifically reserves the right to inspect any truck used in the collection of refuse and Recyclables at any time in order to ensure that the terms of this contract are being adhered to.

## **10. INSURANCE**

**A. WORKMEN'S COMPENSATION INSURANCE:** The Contractor during the term of this contract shall carry workmen's compensation insurance, insuring and covering any and all persons employed by him in the performance of this contract, and before starting work on the contract, shall annually file a certificate from the insurance company certifying the issuance of such company's insurance policy and the payment of the premium thereof with the Township. **An affidavit accepting the provisions of the Pennsylvania Workmen's Compensation Act of 1915 shall be submitted with each proposal.**

**B. LIABILITY INSURANCE:** The Contractor shall maintain, during the term of this contract at its sole expense, the following minimum liability insurance coverage:

- 1) General public liability insurance (non-automotive) for bodily injury and property damage in the amount of \$1,000,000.00 per occurrence but with the aggregate limit of \$2,000,000.00.
- 2) Automotive liability insurance for bodily injury and property damage in the amount of \$1,000,000.00 for each person and \$1,000,000.00 for each occurrence.
- 3) Umbrella excess liability insurance coverage in the amount of \$3,000,000.00.
- 4) Environmental insurance in the amount of \$3,000,000.00.

**C.** The aforesaid policies of insurance and others that may be necessary to comply herewith shall be maintained in the amount set forth above and shall, inter alia, **NAME THE TOWNSHIP AS AN ADDITIONAL NAMED INSURED** and be designed to protect the Township from any and all claims for damage of any kind or any nature whatsoever, including but not limited to wrongful death, which may arise from the obligation of the Contractor in the performance of this contract, whether such obligation be controlled by the Contractor himself or by someone either directly or indirectly employed by him for the purpose of accomplishing some obligation incumbent upon the Contractor by the terms of this contract and shall otherwise indemnify and hold the Township harmless from any and all manner of claims, lawsuits, judgment, damages and executions and shall provide, at the insurer's expense, all necessary legal aid, counsel and representation.

All insurance policies maintained hereunder shall be issued by an insurance carrier licensed and authorized to do business within the Commonwealth of Pennsylvania and shall be obtained and properly endorsed in favor of the Township before the execution of the contract hereunder. Said policy shall remain in full force and effect until the expiration of the term of this contract or any extensions or until completion of all duties to be performed hereunder by the Contractor, whichever shall occur later. The Contractor shall provide the Township the original policies of insurance herein referred to or true copies thereof, prior to commencing work under this contract.

Evidence of said insurance shall be submitted to the Township within fourteen (14) days after notification of the award of contract.

**D. CANCELLATION OF INSURANCE:** Each and every policy of insurance maintained in accordance with the terms of these specifications or the contracts entered hereunder, shall carry with it an endorsement to the effect that the insurance carrier will convey to the Township, by certified mail, return receipt requested, written notice of any modification, alterations or cancellations of any policy or policies or the terms thereof; and said written notice must be received by the Township, at least ten (10) days prior to the effective date of any such modification, alteration or cancellation. If such modifications, alterations or cancellations shall cause the insurance coverage required hereunder to fail to meet the minimum requirement set forth herein, the Contractor shall be deemed to be in default and the Township shall terminate this agreement as of the effective date of said change in insurance coverage and the surety on the performance bond shall be held responsible by the Township for any loss arising as a result thereof.

It shall be the responsibility of the Contractor in obtaining the aforesaid insurance coverage to obtain policies which shall protect the Township from any and all claims whatsoever in nature regardless of the source of said claim and regardless of whether the same are directed toward the recovery of damages for personal injury, property damage or any other claim of damage which may be incident to the same.

**E. GOVERNMENTAL IMMUNITY WAIVER:** All policies of insurance required pursuant to these specifications or the contract(s) entered into therein under, shall waive any governmental immunity, if any, of the Township and shall extend to and include all direct and indirect agents and employees of the Contractors and shall include policies of liability insurance on all vehicles and equipment utilized or in any way connected with the service to be rendered by the Contractor pursuant to the terms of this contract.

**11. HOLD HARMLESS PROVISION:** The Contractor will indemnify and save harmless the Township and all its officers, agents and employees from any actions, liabilities or claims resulting from the performance of the contract or the failure to perform the contract.

**12. EQUAL OPPORTUNITY EMPLOYER:**

The Contractor shall state in writing that it is an Equal Opportunity Employer, and each bidder shall

sign the Affirmative Action Affidavit.

### **13. BONDS:**

**A. Bid Bond:** A bid bond or a certified check in the amount of five percent (5%) of the total bid amount shall be submitted with each proposal. Bid bonds shall be on the form provided and shall be duly executed by the bidder as principal and the surety company. The surety company must be authorized to do business in the Commonwealth of Pennsylvania and the Bid Bond must be accompanied by a Power of Attorney nominating, constituting, and appointing the person whose signature appears on said bid bond as the true and lawful agent of the surety to execute all bonds and the consent on its behalf. Any certified check that is received by the Township in lieu of a Bid Bond will be returned upon execution of the agreement.

In the event that any bidder shall, upon award of the contract to him, fail to execute the agreement, or comply with the requirements of these specifications, the full amount of the Bid Bond or certified check shall be forfeited to the Township as liquidated damages (not a penalty).

A Consent of Surety shall be submitted by which the Surety acknowledges that the bidder, if successful, will be able to provide the Township with a performance bond for 100% of the amount of the contract award, which shall be calculated in accordance with Section 23 Bid Award hereof. **The Consent of Surety shall be on the form provided and submitted with each proposal.**

**B. Performance Bond** The successful bidder will be required to obtain and post a performance bond in the amount of 100% of the amount of the contract award, which shall be calculated in accordance with Section 23 Bid Award hereof. The performance bond shall be submitted within fourteen (14) days after notification of the award of the contract. **The performance bond shall be on the form provided.**

If the Board of Supervisors extends the contract, the Contractor shall within fourteen (14) days after notification provide the Township with an updated performance bond. The performance bond shall be increased by a percentage equal to the change in Consumer Price Index US City Average for All Urban Consumers (CPI-U) for the twelve-month periods ending in December 2026, 2027, 2028, and 2029, as applicable.

**1) Performance Bond and Bond Years:**

a) Prior to the execution of the contract, the successful bidder will be required to furnish a bond for the faithful performance of the contract, in the sum outlined as follows:

3) First Year Bond: 100% of the first-year bid.

4) Second Year Bond: 50% of the second-year Bid, adjusted to include new dwelling units to be submitted to the Township 60 days prior to the end of the first year.

5) Third, Fourth, and Fifth Year Bonds: Same as a second-year Bond.

The initial Bond shall commence on the date on which work is to commence and on each anniversary of such new bond year thereafter.

Said Bond shall be that of an approved surety company authorized to transact business within the Commonwealth of Pennsylvania and proof of same shall be submitted to the satisfaction of the Board of Supervisors. Agents of the bonding company shall furnish the necessary powers of attorney, bearing the seal of the company and evidencing such agents' authorizations to execute the particular type of bond to be furnished, as well as the right of the surety company to conduct business in the Commonwealth of Pennsylvania.

**14. SCHEDULE OF PAYMENTS:** The Township shall pay the Contractor monthly, for the collection of Municipal Waste, Yard Waste, Bulk Trash items, and recyclable materials completed in accordance with these specifications.

**15. DRUG AND ALCOHOL TESTING PROGRAM:** The Omnibus Transportation Employee Testing Act of 1991 requires drug and alcohol testing for safety-sensitive employees in the aviation, motor carrier, and mass transit industries, and required the U.S. Department of Transportation to promulgate rules mandating and regulating anti-drug and alcohol misuse prevention programs.

In addition to the above, all employees that load the refuse and recycling trucks with the Municipal Waste, Yard Waste, Bulk Trash items, and Recyclable Materials shall participate in a drug testing program.

**An affidavit confirming the above shall be submitted with each proposal.**

**16. BID AWARD:** The Township will determine the low bidder by evaluating the Total Costs as listed on the Cost Breakdown.

If the total costs on any proposal are found to be computed incorrectly, the Township reserves the right to make such changes as are necessary in the extended amounts and total costs on the basis of the unit prices given and the quantities stated for the scheduled items therein.

**The Board of Supervisors of East Goshen Township reserves the right to waive technicalities, to reject any or all bids or items herein, and to make the award that is in the**

**best interests of the Township.**

**17. ADDENDA:** Any revision or interpretation of the bid specifications prior to the bid opening will be in the form of an addendum that will be posted on the East Goshen Township website, [www.eastgoshen.org](http://www.eastgoshen.org) (See “RFPs and Bid Notices” under the “About Us” tab), and emailed to each bidder. Each bidder shall be responsible for reviewing the East Goshen Township Website for Addendum as they are posted.



## EAST GOSHEN TOWNSHIP 2026 MUNICIPAL WASTE AND RECYCLABLE MATERIALS CONTRACT BID PROPOSAL FORM

(Please print or type)

Date: \_\_\_\_\_

Firm Name: \_\_\_\_\_

Address: \_\_\_\_\_

\_\_\_\_\_

Contact Person: \_\_\_\_\_

Telephone: \_\_\_\_\_

E-Mail: \_\_\_\_\_

This proposal is submitted in accordance with the advertisement inviting bids to be received by East Goshen Township at the Township Building, 1580 Paoli Pike, West Chester, PA, 19380, for the collection of Municipal Waste and Recyclable Materials.

**Notice to Contractor:**

The email address designated in the bid or proposal is hereby designated as the address to which all notices, letters, and other communications shall be sent.

After examining all parts of this project for supplying of collection services for Municipal Waste and Recyclable Materials; and service to municipal facilities, we have read and understand the specifications as set forth in the Instructions to Bidders, and hereby propose to furnish said services in strict accordance with all specifications for the sums indicated, and the undersigned herein agrees to furnish all labor, materials, and equipment and to perform all work necessary to complete in a workmanlike manner, the work described in the above-mentioned contract, in accordance with said contract documents to the satisfaction and acceptance of the Township, for the sums stated on the Cost Breakdown.

<b>TOTAL, RESIDENTIAL COLLECTIONS:</b> (from Cost Breakdown, p. 30)	
<b>TOTAL, TOWNSHIP FACILITIES:</b> (from Cost Breakdown, p. 31)	
<b>GRAND TOTAL:</b>	

In submitting this proposal, it is understood that it is the right of the Township to reject any or all proposals or parts thereof, and to waive any informalities or technicalities in said proposals. This proposal shall remain firm for at least ninety (90) days from bid opening.

The undersigned further agrees that he or it possesses the necessary skill required to determine the adequacy of the Township's bid specifications for the purpose of arriving at the contract price, and that he has exercised this skill and **that he finds them fit and sufficient for the purpose intended and free from ambiguities**, and also has carefully examined the Instructions to Bidders and other Contract Documents, including the addenda listed below, and the site of the work, and from his own investigations, has satisfied himself as to the nature and location of the work, the character of the work to be encountered, the equipment, and other facilities needed for the performance of the work, the general and local conditions, and other matters which may in any way affect the work or its performance and that he has complied with every requirement of this invitation.

Addenda (list addenda):

---

---

---

Accompanying this proposal is a certified check or bid bond in the amount of **ONE HUNDRED THOUSAND (\$100,000.00) DOLLARS** made payable to the Township, which it is agreed will be forfeited as liquidated damages if the undersigned fails to execute the contract and furnish the performance bond and evidence of insurance, as specified, within 14 days after notification of the award of the contract is mailed to him at the official address of the undersigned below.

Accompanying this Bid Proposal Form are the:

1. Cost Breakdown
2. Bidder's Questionnaire
3. Equipment List
4. Affidavit of Authorization to Execute the Proposal Form
5. Affidavit Accepting the Provisions of the Workmen's Compensation Act
6. Affidavit of Non-Collusion
7. Affidavit accepting the provisions of the Omnibus Transportation Employee Testing Act of 1991
8. Affirmative Action Affidavit
9. Bid Bond
10. Consent of Surety Company

(IF A CORPORATION)

Attest:

_____	_____
Name	Name of Corporation
_____	_____
Title	Address
	_____
	City, State, Zip Code

(Seal)

Incorporated under the laws of the State of \_\_\_\_\_.

and (has, has not) been granted a Certificate of Authority to do business in the Commonwealth of Pennsylvania.

(IF AN INDIVIDUAL OR A PARTNERSHIP)

Witness:

\_\_\_\_\_  
\_\_\_\_\_  
\_\_\_\_\_

Signed:

\_\_\_\_\_

Address

\_\_\_\_\_

City, State, Zip Code

\_\_\_\_\_

Witness:

\_\_\_\_\_  
\_\_\_\_\_  
\_\_\_\_\_

Partner

\_\_\_\_\_

Partner

\_\_\_\_\_

Partner

\_\_\_\_\_

\* \_\_\_\_\_ is a co-partnership trading and doing  
business under this firm name with \_\_\_\_\_ as partners.

\* \_\_\_\_\_

is an individual or partnership under a fictitious name and (has, has not) registered under the  
Fictitious Name Act of the Commonwealth of Pennsylvania.



## EAST GOSHEN TOWNSHIP 2026 MUNICIPAL WASTE AND RECYCLABLE MATERIALS CONTRACT

### COST BREAKDOWN

Firm Name: \_\_\_\_\_

Item #	<b>RESIDENTIAL COLLECTION</b>			
	<b>MUNICIPAL WASTE - 3383 DWELLING UNITS</b>		<b>COST PER DWELLING UNIT</b>	<b>TOTAL FOR 3383 DWELLING UNITS</b>
<b>1</b>	Option 1	MONTHLY COST - ONE PICKUP PER WEEK		
<b>2</b>	Option 2	MONTHLY COST - TWO PICKUPS PER WEEK		
	<b>RECYCLABLES - 3383 DWELLING UNITS</b>		<b>COST PER DWELLING UNIT</b>	<b>TOTAL FOR 3383 DWELLING UNITS</b>
<b>3</b>	1	MONTHLY COST - ONE PICKUP PER WEEK		
	<b>YARD WASTE - 3383 DWELLING UNITS</b>		<b>COST PER DWELLING UNIT</b>	<b>TOTAL FOR 3383 DWELLING UNITS</b>
<b>4</b>	Option 1	MONTHLY COST - ONE PICKUP PER WEEK		
<b>5</b>	Option 2	MONTHLY COST - BI-WEEKLY PICKUP		
	<b>BULK TRASH - 3383 DWELLING UNITS</b>		<b>COST PER DWELLING UNIT</b>	<b>TOTAL FOR 3383 DWELLING UNITS</b>
<b>6</b>	Option 1	MONTHLY COST - ONE PICKUP PER WEEK		
<b>7</b>	Option 2	MONTHLY COST - ONE PICKUP PER MONTH		
	<b>TOTAL, RESIDENTIAL COLLECTION:</b>			
	Total all amounts listed in the column labelled, "Total for 3383 Dwelling Units" Items 1+2+3+4+5+6+7			



**EAST GOSHEN TOWNSHIP 2026 MUNICIPAL WASTE AND  
RECYCLABLE MATERIALS CONTRACT**

**COST BREAKDOWN**

Firm Name: \_\_\_\_\_

<b>TOWNSHIP FACILITIES</b>		<b>COST</b>
<b>1</b>	<b>TOWNSHIP BUILDING, 1580 PAOLI PK</b>	
a	CONTRACTOR-PROVIDED MUNICIPAL WASTE DUMPSTER, ONCE PER WEEK SERVICE	
b	TWO TO THREE 96-GALLON TOWNSHIP-PROVIDED RECYCLING TOTES, ONCE PER WEEK SERVICE	
c	30-YARD ROLL-OFF CONTRACTOR PROVIDED MUNICIPAL WASTE DUMPSTER, SERVICED ON AS-NEEDED BASIS	
	<b>TOTAL FOR TOWNSHIP BUILDING:</b>	
<b>2</b>	<b>TOWNSHIP PARK, 1661 PAOLI PK</b>	
a	TWO THREE-YARD CONTRACTOR-PROVIDED MUNICIPAL WASTE DUMPSTERS, ONCE PER WEEK SERVICE	
	<b>TOTAL FOR TOWNSHIP PARK:</b>	
<b>3</b>	<b>RIDLEY CREEK SEWER TREATMENT PLANT (RCSTP), 1751 TOWNE DR</b>	
a	ONE THREE-YARD CONTRACTOR-PROVIDED MUNICIPAL WASTE DUMPSTER, ONCE PER WEEK SERVICE	
b	TRANSPORT TOWNSHIP-OWNED 20-YARD SLUDGE DUMPSTER FROM RCSTP TO LANCHESTER LANDFILL TO BE EMPTIED AND RETURNED TO ORIGINAL LOCATION WITH A CONTRACTOR-PROVIDED LINER, SERVICED ON AS-NEEDED BASIS	
	<b>TOTAL FOR RCSTP:</b>	
<b>TOTAL, TOWNSHIP FACILITIES:</b>		



## EAST GOSHEN TOWNSHIP 2026 MUNICIPAL WASTE AND RECYCLABLE MATERIALS CONTRACT

### BIDDER'S QUESTIONNAIRE

Each bidder shall provide the following information as an integral part of their bid; and failure to answer all questions will render such bid as irregular and non-responsive.

1. How many years' experience in the collection of municipal waste and recyclable materials in municipalities does your organization (bidder and/or bidder's parent subsidiary or affiliated corporations) have? \_\_\_\_\_
  
2. List the municipalities you or your organization are now providing collection services for, the number of units serviced in each municipality, and the names of the responsible municipal official in each to whom you report:

Municipality Serviced	Number of Units	Report To
_____	_____	_____
_____	_____	_____
_____	_____	_____

3. Indicate the local telephone number(s) and email(s) for your office which will be available to receive service inquiries from both the residents of the Township and Township officials:

1)	_____		
Name	Phone	Email	
2)	_____		
Name	Phone	Email	

4. What equipment do you intend to obtain and use for the performance of the service contract? Per Section 4.02.G of the Specifications, all equipment that the Contractor uses in the performance of the work shall be no more than five (5) years old.  
(Please complete the attached Equipment List)

5. Have you or your organization, or any partners or officers thereof, failed to complete a municipal collection contract for any reason or defaulted under any such contract? \_\_\_\_\_

If so, where? \_\_\_\_\_

6. Is your company associated with any other companies, either directly and/or indirectly? \_\_\_\_\_

a. If yes, give details: \_\_\_\_\_

\_\_\_\_\_

7. Did you or your organization, or any partners or officers thereof, withdraw a bid when you were the lowest bidder on a municipal collection contract? \_\_\_\_\_

a. If yes, for what reason? \_\_\_\_\_

\_\_\_\_\_

8. Did you or your organization, or any partners or officers thereof, attempt to sell your bid when you were the lowest bidder on a municipal collection contract? \_\_\_\_\_

a. If yes, for what reason? \_\_\_\_\_

\_\_\_\_\_

9. Have you or your organization, or any partners or officers thereof, been a party to any lawsuits or legal actions, whether of a civil or criminal nature, arising out of or involving bid contracts or the performance thereof? \_\_\_\_\_

a. If yes, give details of all such matters that have been filed in the last five years:

\_\_\_\_\_

\_\_\_\_\_

10. Are there any unsatisfied judgments recorded against you, your organization, or any partners or officers thereof? \_\_\_\_\_

a. If yes, give details, including the name and address of each judgment creditor, and the

amount of each judgment: \_\_\_\_\_

\_\_\_\_\_



I, \_\_\_\_\_, being duly sworn according to law upon my oath depose and say:

1. I am the \_\_\_\_\_  
(Title)

of \_\_\_\_\_,  
(Bidding Company Name)

the bidder named herein, and I am duly authorized to respond to foregoing questions on the East Goshen Township 2026 Municipal Waste and Recyclable Materials Contract Bidder's Questionnaire on behalf of said bidder.

2. I have read the foregoing questions and the answers which I have submitted in response thereto are true and correct in all respects to the best of my knowledge, information, and belief.

\_\_\_\_\_  
(Name and Title)

\_\_\_\_\_  
(Company)

Sworn and subscribed before me

This \_\_\_\_\_ day of \_\_\_\_\_, 2026.

\_\_\_\_\_  
(Notary Public)

SEAL

**AFFIDAVIT**

**OF AUTHORIZATION TO EXECUTE THE PROPOSAL FORM**

\_\_\_\_\_ being first duly sworn, deposes and  
(Printed Name)

says that s/he is the \_\_\_\_\_  
(Title)

of \_\_\_\_\_  
(Company Name)

who signed the foregoing proposal that s/he was duly authorized to sign on their behalf, and that the bid is the true offer of the bidder and that all declarations and statements contained in the bid are true to the best of her/his knowledge and belief.

\_\_\_\_\_  
(Signature of the person named above)

Sworn to and subscribed by me

this \_\_\_\_\_ day of \_\_\_\_\_, 2026.

\_\_\_\_\_  
Notary Public

SEAL

**AFFIDAVIT**

**ACCEPTING THE PROVISIONS OF THE WORKMEN'S COMPENSATION ACT**

\_\_\_\_\_ being first duly sworn, deposes and  
(Printed Name)

says that s/he is the \_\_\_\_\_  
(Title)

of \_\_\_\_\_  
(Company Name)

who submitted the foregoing proposal or bid; and that he or it has accepted the provisions of the Workmen's Compensation Act of 1915 of the Commonwealth of Pennsylvania, with its supplements and amendments and have insured their liability hereunder in accordance with the terms of said Act with:

\_\_\_\_\_  
(Name of Surety Company)

\_\_\_\_\_  
(Signature of the person named above)

Sworn to and subscribed by me

this \_\_\_\_\_ day of \_\_\_\_\_, 2026.

\_\_\_\_\_  
Notary Public

SEAL

**AFFIDAVIT OF NON-COLLUSION**

\_\_\_\_\_ first duly sworn, deposes and says  
(Printed Name)

that s/he is the \_\_\_\_\_  
(Title)

of \_\_\_\_\_  
(Company Name)

who signed the above proposal or bid on behalf of the party making the foregoing proposal or bid; that s/he was duly authorized to sign on their behalf; that the bid is the true offer of the bidder; that such bid is genuine and not collusive or a sham, that said bidder has not colluded, conspired, connived or agreed, directly or indirectly, with any bidder or person, to put in a sham bid, or that such other person shall refrain from bidding, and has not in any manner, directly or indirectly sought by agreement or collusion, or communication or conference with any person, to fix the bid price of affiant or any other bidder, or to fix any overhead, profit or cost element of said bid price, or that of any other bidder, or to secure any advantage against the Township or any person interested in the proposed contract; and that all declarations and statements contained in said proposal or bid are true to the best of his knowledge or belief; and, further, that such bidder has not directly or indirectly submitted this bid, or the contents hereof, or divulged information or data thereto to any association or to any member or agent thereof.

\_\_\_\_\_  
(Signature of the person named above)

Sworn to and subscribed by me

this \_\_\_\_\_ day of \_\_\_\_\_, 2026.

\_\_\_\_\_  
Notary Public

SEAL

**AFFIDAVIT**

**ACCEPTING THE PROVISIONS OF OMNIBUS  
TRANSPORTATION EMPLOYEE TESTING ACT OF 1991  
AND  
CONFIRMING THAT OTHER EMPLOYEES INVOLVED  
WITH THE COLLECTION OF MUNICIPAL WASTE AND RECYCLABLES  
PARTICIPATE IN A DRUG TESTING PROGRAM**

\_\_\_\_\_ being first duly sworn, deposes and  
(Printed Name)

says that s/he is the \_\_\_\_\_  
(Title)

of \_\_\_\_\_  
(Company Name)

who submitted the foregoing proposal or bid; and that s/he or it has accepted the provisions of the Omnibus Transportation Employee Testing Act of 1991 and that they are participating in a Drug and Alcohol Program as required by this Act and the employees that load and transport the Municipal Waste, Recyclable Materials, Yard Waste, and Bulk Trash items, and participate in a drug testing program.

\_\_\_\_\_  
(Signature of the person named above)

Sworn to and subscribed by me

this \_\_\_\_\_ day of \_\_\_\_\_, 2026.

\_\_\_\_\_  
Notary Public

SEAL

**AFFIRMATIVE ACTION AFFIDAVIT**

I, \_\_\_\_\_, being duly sworn, depose and say that I  
(Name of Affiant)

reside at \_\_\_\_\_, and that I am

the \_\_\_\_\_  
(Title)

of \_\_\_\_\_  
(Name of Company)

in such capacity and for and on behalf of \_\_\_\_\_,  
it is hereby affirmed and agreed as follows:

1. \_\_\_\_\_  
(Name of Bidding Company)  
will not discriminate against an employee or applicant for employment because of  
age, race, creed, color, national origin, ancestry, marital status, or sex.

2. \_\_\_\_\_  
(Name of Bidding Company)  
will take affirmative action to ensure that all applicants are recruited and employed and that  
employees are treated during employment without regard to their age, race, creed, color, national  
origin, ancestry, marital status, or sex. Such action shall include, but shall not be limited to, the  
following: employment, upgrading, demotion, or transfer; recruitment or recruitment advertising,  
layoff or termination rates of pay or other forms of compensation, and selection for training including  
apprenticeship.

3. \_\_\_\_\_  
(Name of Bidding Company)  
will in all solicitations or advertisements for employees state that all qualified applicants will receive  
consideration for employment without regard to age, race, creed, color, national origin, ancestry, marital  
status, or sex.

\_\_\_\_\_  
(Affiant)

\_\_\_\_\_  
(Name of Company)

Sworn and subscribed to before me this \_\_\_\_\_ day of \_\_\_\_\_, 2026.

\_\_\_\_\_  
Notary Public

SEAL

**EAST GOSHEN TOWNSHIP  
MUNICIPAL WASTE AND RECYCLABLE MATERIALS COLLECTION CONTRACT**

**BID BOND**

BIDDER (Name and Address):

\_\_\_\_\_

\_\_\_\_\_

\_\_\_\_\_

SURETY (Name and Address of Principal Place of Business):

\_\_\_\_\_

\_\_\_\_\_

---

OWNER (Name and Address):

East Goshen Township  
1580 Paoli Pike  
West Chester PA 19380

BID

BID DUE DATE: \_\_\_\_\_

PROJECT: For the collection of Municipal Waste, Recyclable Materials, Yard Waste, and Bulk Trash items in East Goshen Township

BOND

BOND NUMBER: \_\_\_\_\_

DATE (Not later than Bid Due Date): \_\_\_\_\_

PENAL SUM: \_\_\_\_\_

IN WITNESS WHEREOF, Surety and Bidder, intending to be legally bound hereby, subject to the terms herein, do each cause this Bid Bond to be duly executed on its behalf by its authorized officer, agent, or representative.

**EAST GOSHEN TOWNSHIP  
MUNICIPAL WASTE AND RECYCLABLE MATERIALS COLLECTION CONTRACT**

**BID BOND**

BIDDER

SURETY

\_\_\_\_\_ (Seal) \_\_\_\_\_ (Seal)  
Bidders Name and Corporate Seal      Surety's Name and Corporate Seal

By: \_\_\_\_\_  
Signature

By: \_\_\_\_\_  
Signature (Attach Power of Attorney)

\_\_\_\_\_  
Title

\_\_\_\_\_  
Title

Attest: \_\_\_\_\_  
Signature

Attest: \_\_\_\_\_  
Signature

\_\_\_\_\_  
Title

\_\_\_\_\_  
Title

- 
- Note: (1) Above addresses are to be used for giving notice.  
(2) Any singular reference to Bidder, Surety, Owner, or other party shall be considered plural where applicable.
- 

1. Bidder and Surety, jointly and severally, bind themselves, their heirs, executors, administrators, successors, and assigns to pay to Owner upon default of Bidder any difference between the total amount of Bidder's bid, including any accepted Alternates, and the total amount of the bid of the next lowest, responsible and responsive bidder as determined by Owner for the Work required by the Contract Documents, provided that:
  - 1.1. If there is no such next lowest, responsible and responsive bidder, and Owner does not abandon the Project, then Bidder and Surety shall pay to Owner the penal sum set forth on the face of this Bond, and
  - 1.2. In no event shall Bidder's and Surety's obligation hereunder exceed the penal sum set forth on the face of this Bond.
  
2. Default of Bidder shall occur upon the failure of Bidder to deliver within the time required by the Bidding Documents (or any extension thereof agreed to in writing by Owner) the executed Agreement required by the Bidding Documents and any performance and payment bonds required by the Bidding Documents and Contract Documents.
  
3. This obligation shall be null and void if:
  - 3.1. Owner accepts Bidder's bid and bidder delivers within the time required by the Bidding Documents (or any extension thereof agreed to in writing by Owner) the executed Agreement required by the Bidding Documents and any performance and payment bonds required by the Bidding Documents and Contract Documents, or
  - 3.2. All bids are rejected by Owner, or
  - 3.3. Owner fails to issue a notice of award to Bidder within the time specified in the Bidding Documents (or any extension thereof agreed to in writing by Bidder and, if applicable, consented to by Surety when required by paragraph 5 hereof).
  
4. Payment under this Bond will be due and payable upon default by Bidder and within 30 calendar days after receipt by Bidder and Surety of written notice of default from Owner, which notice will be given with reasonable promptness, identifying this Bond and the Project and including a statement of the amount due.
  
5. Surety waives notice of and any and all defenses based on or arising out of any time extension to issue notice of award agreed to in writing by Owner and Bidder, provided that the total time for issuing notice of award including extensions shall not in the aggregate exceed 120 days from Bid Due Date without Surety's written consent.
  
6. No suit or action shall be commenced under this Bond prior to 30 calendar days after the notice of default required in paragraph 4 above is received by Bidder and Surety and in no case later than one year after Bid Due Date.

7. Any suit or action under this Bond shall be commenced only in a court of competent jurisdiction located in the state in which the Project is located.

8. Notices required hereunder shall be in writing and sent to Bidder and Surety at their respective addresses shown on the face of this Bond. Such notices may be sent by personal delivery, commercial courier or by United States Registered or Certified Mail, return receipt requested, postage pre-paid, and shall be deemed to be effective upon receipt by the party concerned.

9. Surety shall cause to be attached to this Bond a current and effective Power of Attorney evidencing the authority of the officer, agent or representative who executed this Bond on behalf of Surety to execute, seal and deliver such Bond and bind the Surety thereby.

10. This Bond is intended to conform to all applicable statutory requirements. Any applicable requirement of any applicable statute that has been omitted from this Bond shall be deemed to be included herein as if set forth at length. If any provision of this Bond conflicts with any applicable provision of any applicable statute, then the provision of said statute shall govern and the remainder of this Bond that is not in conflict therewith shall continue in full force and effect.

11. The term "bid" as used herein includes a bid, offer or proposal, inclusive of all Alternates, as applicable.

**CONSENT OF SURETY COMPANY**

IN ACCORDANCE with the provisions of the bid dated \_\_\_\_\_,

Between \_\_\_\_\_ East Goshen Township \_\_\_\_\_  
(Owner)

and \_\_\_\_\_  
(Contractor)

the \_\_\_\_\_  
(Surety)

SURETY on the Bid Bond of

\_\_\_\_\_  
(Contractor)

acknowledges that Contractor, if awarded the Bid will provide to Owner a Performance Bond in the amount of 100% of the amount of the contract award.

IN WITNESS WHEREOF, said SURETY has hereunto set its hand and seal this \_\_\_\_\_ day of \_\_\_\_\_, 2026.

ATTEST: \_\_\_\_\_  
Signature

\_\_\_\_\_  
Title

SURETY: \_\_\_\_\_  
Signature

\_\_\_\_\_  
Title

NOTE: This statement, if executed by any person other than the President or Vice President of the Company, must be accompanied by a certificate of even date showing authority conferred upon the person so signing to execute such instruments on behalf of the Company represented.

**PERFORMANCE BOND**

**KNOW ALL PERSONS BY THESE PRESENTS** that we,

\_\_\_\_\_ (Name of Contractor) of

\_\_\_\_\_ (Address of Contractor), as Principal (the

"Principal"), and \_\_\_\_\_ (Name of Surety), a

corporation organized and existing under laws of the State of \_\_\_\_\_, with

its principal place of business at \_\_\_\_\_

\_\_\_\_\_ (Address of Surety)

(the "Surety"), are held and firmly bound unto East Goshen Township (the "Obligee"), as

hereinafter set forth, in the full and just sum of:

\_\_\_\_\_ Dollars (\$ \_\_\_\_\_)

lawful money of the United States of America, for the payment of which sum we bind ourselves, our heirs, executors, administrators, successors, and assigns, jointly and severally, firmly by these presents.

**WITNESSETH THAT:**

**WHEREAS**, Principal heretofore has submitted to the Obligee a certain proposal, dated \_\_\_\_\_, 2026 (the "Proposal"), for the collection of Municipal Waste, Recyclable Materials, Yard Waste, and Bulk Trash pursuant to Instructions to Bidders and other related documents constituting the contract documents, which are incorporated into the Proposal by reference (the "Contract Documents"); and

**WHEREAS**, the Obligee is a "contracting body" under provisions of Act No. 385 of the General Assembly of the Commonwealth of Pennsylvania, approved by the Governor on December 20, 1967, known and sited as the "Public Works Contractor's Bond Law of 1967" (the "Act"); and

**WHEREAS**, the Act, in Section 3(a), requires that, before an award shall be made to the Principal by the Obligee in accordance with the Proposal, the Principal shall furnish this Bond to the Obligee, with this Bond to become binding upon the award of a contract to the Principal by the Obligee in accordance with the Proposal; and

**WHEREAS**, it also is a condition of the Contract Documents that this Bond shall be furnished by the Principal to the Obligee; and

**WHEREAS**, under the Contract Documents, it is provided, *inter alia*, that if the Principal shall furnish this Bond to the Obligee, and if the Obligee makes an award to the Principal in accordance with the Proposal, then the Obligee may require the Principal to enter into an agreement with respect to performance of such work (the "Agreement"), the form of which Agreement is set forth in the Contract Documents.

**NOW, THEREFORE**, the terms and conditions of this Bond are and shall be that:

If the Principal well, truly and faithfully shall comply with and shall perform the Agreement in accordance with the Contract Documents, at the time and in the manner provided in the Agreement and in the Contract Documents, and if the Principal shall satisfy all claims and demands incurred in or related to the performance of the Agreement by the Principal, and if the Principal shall indemnify completely and shall save harmless the Obligee and all of its officers, agents and employees from any and all costs and damages which the Obligee and all of its officers, agents and employees may sustain or suffer by reason of the failure of the Principal to do so, and if the Principal shall reimburse completely and shall pay to the Obligee any and all costs and expenses, including attorney's fees, which the Obligee and all of its officers, agents, and employees may incur by reason of any such default or failure of the Principal.

This Bond is executed and delivered under and subject to the Act, to which reference hereby is made.

The Principal and the Surety agree that any alterations, changes and/or additions to the Contract Documents, and/or any alterations, changes and/or additions to the work to be performed under the Agreement in accordance with the Contract Documents, and/or any alterations, changes and/or additions to the Agreement and/or any giving by the Obligee of any extensions of time for the performance of the Agreement in accordance with the Contract Documents, and/or any act of forbearance of either the Principal or the Obligee toward the other with respect to the Contract Documents and the Agreement, and/or the reduction of any percentage to be retained by the Obligee as permitted by the Contract Documents and by the Agreement, shall not release, in any manner whatsoever, the Principal and the Surety, or either of them, or their heirs, executors, administrators, successors, and assigns, from liability and obligations under this Bond; and the Surety, for value received, does waive notice of any such alterations, changes, additions, extensions of time, acts of forbearance and/or reduction of retained percentage.

Provided that it is expressly agreed that this Bond shall be deemed amended automatically and immediately, without formal and separate amendments hereto, upon amendment to the Agreement or the Contract Documents not increasing the Contract price more than twenty percent (20%), so as to bind the Principal and the Surety to the full and faithful performance of the

Agreement and the Contract Documents as so amended. The term "Amendment", wherever used in this Bond and whether referring to this Bond, the Agreement or the Contract Documents, shall include any alteration, addition, extension, or modification of any character whatsoever.

Provided, further, that no final settlement between the Obligee and the Principal shall abridge the right of any beneficiary hereunder, whose claim may be unsatisfied.

The Surety shall not be liable in the aggregate to the Obligee for more than the total sum set forth above. The Surety may elect to make any payment hereunder to either Obligee or both, by its check issued jointly or individually.

**IN WITNESS WHEREOF**, the Principal and the Surety cause this Bond to be signed, sealed and delivered this \_\_\_\_\_ day of \_\_\_\_\_, 2026.

***(Individual Principal)***

WITNESS:

\_\_\_\_\_  
(Signature of Individual)

Trading and doing business as: \_\_\_\_\_.

***(Partnership Principal)***

WITNESS:

\_\_\_\_\_  
(Signature of Individual)

\_\_\_\_\_  
(Name of Partnership)

By: \_\_\_\_\_ (SEAL)  
(Partner)

**(Corporation Principal)**

\_\_\_\_\_  
(Name of Corporation)

By:

\_\_\_\_\_  
(Vice) President

ATTEST:

\_\_\_\_\_  
(Assistant) Secretary

(CORPORATE SEAL)

*or (if appropriate)*

WITNESS:

\_\_\_\_\_  
(Name of Corporation)

\*By: \_\_\_\_\_  
(Authorized Representative)

(CORPORATE SEAL)

*\*Attach appropriate proof, dated as of the same date as the Bond, evidencing authority to execute on behalf of the corporation.*

**(Corporate Surety)**

WITNESS:

\_\_\_\_\_  
(Name of Corporation)

\*\*By: \_\_\_\_\_  
(Attorney-in-fact)

(CORPORATE SEAL)

*\*\*Attach an appropriate power of attorney, dated as of the same date as the Bond, evidencing the authority of the Attorney-in-fact to act on behalf of the corporation.*



**EAST GOSHEN TOWNSHIP  
MUNICIPAL WASTE AND RECYCLABLE MATERIALS COLLECTION CONTRACT  
AGREEMENT BETWEEN EAST GOSHEN TOWNSHIP AND CONTRACTOR**

THIS AGREEMENT, made the \_\_\_\_\_ day of \_\_\_\_\_, in the year 2026,  
by and between \_\_\_\_\_,  
hereinafter called the CONTRACTOR, and East Goshen Township, Chester County,  
Pennsylvania, hereinafter called the TOWNSHIP.

Witnessed that the CONTRACTOR and the TOWNSHIP for the considerations hereafter named,  
agree as follows:

**ARTICLE 1 - SCOPE OF WORK:** The CONTRACTOR shall furnish all the materials, equipment, and labor and will perform all of the work for the collection of Municipal Waste, Recyclable Materials, Yard Waste, and Bulk Trash items in accordance with the contract documents.

**ARTICLE 2 - THE CONTRACT:** The TOWNSHIP shall pay the CONTRACTOR for the performance of the contract, in accordance with the contract documents at the first regularly scheduled meeting of the Board of Supervisors after receipt of the invoice.

**ARTICLE 3 - THE CONTRACT DOCUMENTS:** This Agreement and the following enumerated documents form the Contract, and they are as fully a part of the Contract as if attached hereto or hereinafter repeated and are termed the Contract Documents.

1. Notice to Bidders
2. East Goshen Township Municipal Waste and Recyclable Materials Collection Contract
3. Bid Proposal Form
4. Cost Breakdown
5. Bidder's Questionnaire
6. Equipment List
7. Affidavit of Authorization to Execute the Proposal Form
8. Affidavit Accepting the Provisions of the Workmen's Compensation Act
9. Affidavit of Non-Collusion
10. Affidavit Accepting the Provisions of the Omnibus Transportation Employee Testing Act of 1991
11. Affirmative Action Affidavit
12. Bid Bond
13. Consent of Surety Company
14. Performance Bond
15. Addenda (if applicable)
16. East Goshen Township Municipal Waste and Recycling Ordinance
17. Chester County and East Goshen Township Recyclable Process & Marketing Agreement (new agreement starts September 26, 2026)
18. Total Recycle, Inc. Recycling List

ARTICLE 4 - COMMENCEMENT TIME: The CONTRACTOR hereby agrees to commence work under this contract on January 1, 2027.

IN WITNESS WHEREOF, the parties hereto set their hands and seal the day and year first above written.

**EAST GOSHEN TOWNSHIP:**

BOARD OF SUPERVISORS

---

---

---

---

---

---

Township Secretary

**CONTRACTOR:**

---

Signature

---

Title

# MEMO

Date: May 28, 2026

From: Derek Davis, Township Manager

To: Board of Supervisors

Re: Solar Feasibility Results

---

As approved by the board last meeting, *PA Solar Center* was able to conduct the East Goshen Feasibility Study, which is essentially a very straight forward assessment to let us know of the approximate return on investment for solar panel installation on our township campus based on the amount of square footage we have to actually install a system. We will be discussing the results and presenting the document at the meeting. The document itself will also be posted online shortly after the board meeting on June 2<sup>nd</sup>.

610-692-7171  
www.eastgoshen.org

**BOARD OF SUPERVISORS**  
EAST GOSHEN TOWNSHIP  
CHESTER COUNTY  
1580 PAOLI PIKE, WEST CHESTER, PA 19380-6199

To: Board of Supervisors  
From: Mark Miller  
Date: May 7, 2026  
Re: Line Painting Bid with West Goshen

Please acknowledge that the line painting bid was advertised, opened, and awarded by West Goshen Township to Alpha Space Control, LLC in the amount of \$223,384.50. The is an a la carte contract for six municipalities that have joined forces to procure these services.

East Goshen spent \$39,563.50 on line painting in 2025 and we expect to spend close to the same amount this year.

The markings needed by East Goshen in 2026 are:

- Double Yellow Lines
- White Edge Lines (Single White Lines)
- Stop Bars
- Arrows



MEMORANDUM

From the Office of the  
Township Manager

---

TO: BOARD OF SUPERVISORS  
FROM: CHRISTOPHER BASHORE  
RE: 2026 PAVEMENT MARKING BIDS  
DATE: MAY 5, 2026

---

Before the Board of Supervisors this evening are the bid results for the 2026 pavement marking project. The bids were advertised in the April 9, 2026 and April 16, 2026 editions of the Daily Local News. The bids were opened on April 30, 2026. Please see the bid results below:

<u>Company</u>	<u>Address</u>	<u>Bid Amount</u>
A-1 Traffic Control Products, LLC	6 Unionville Road Douglasville, PA 19518	\$168,164.50
Alpha Space Control, LLC	1580 Gabler Road Chambersburg, PA 17201	\$223,384.50
D.E. Gemmill, Inc.	10174 Chapel Church Road Red Lion, PA 17356	\$268,079.92

Please be advised that in reviewing the bids, A-1 Traffic Control Products, LLC did not bid on a large portion of the items listed. Their bid was only for the single-white and double-yellow lines. We would consider this to be non-responsive.

Please be advised that this project is shared among the following municipalities:

- West Goshen Township
- East Goshen Township
- Westtown Township
- Uwchlan Township
- Upper Uwchlan Township
- West Whiteland Township

As in the past, each municipality will be billed based on their proportionate share of the work completed. In reviewing past expenditures on this, please note the following:

- 2025 – \$60,112
- 2024 – \$66,023
- 2023 – \$78,405
- 2022 – \$81,848
- 2021 – \$48,379
- Average over the last five (5) years = \$66,953

Please let me know if you have any questions. Thank you.

**Attachment #1  
Schedule of Prices- Painted Markings**

Type of Marking	Unit of Measure	Amount	Cost Per Unit	Total Cost
Broken White Line	Linear Foot			
Single White Line	Linear Foot	523600 L.F.	\$ 0.072	\$ 37699.20
Double Yellow Line	Linear Foot	323300 L.F.	\$ 0.142	\$ 45,908.60
Single Yellow Line	Linear Foot	30975 L.F.	\$ 0.07	\$ 2168.25
Single Yellow & Broken Yellow Lines	Linear Foot		\$	\$
6" White Hash Marks	Linear Foot	50 L.F.	\$ 2.25	\$ 112.50
24" White Gore Marks	Linear Foot	2426 L.F.	\$ 4.00	\$ 9704.00
24" Yellow Gore Marks	Linear Foot	3950 L.F.	\$ 4.00	\$ 15,800.00
6" Crosswalks	Linear Foot	4114 L.F.	\$ 2.35	\$ 9667.90
Arrows	Per Unit	162	\$ 55.00	\$ 8910.00
Onlys	Per Unit	121	\$ 75.00	\$ 9075.00
24" Stop Bar	Linear Foot	4250 L.F.	\$ 4.00	\$ 17,000.00
Stop Legends	Per Unit	12	\$ 75.00	\$ 900.00
Ahead Legends	Per Unit	2	\$ 95.00	\$ 190.00
1' Vascar Lines	Linear Foot	922 L.F.	\$ 4.00	\$ 3688.00
Parking Lot Spaces	Linear Foot	3571 L.F.	\$ 1.50	\$ 5356.50
Handicap Spaces	Per Unit	5	\$ 35.00	\$ 175.00
Trail Crossing	Linear Foot	4	\$ 225.00	\$ 900.00

<b>TOTAL</b>	\$ 167,254.95
--------------	---------------

**Attachment #2  
Schedule of Prices  
Thermoplastic Markings**

Type of Marking	Unit of Measure	Amount	Cost Per Unit	Total Cost
Broken White Line	Linear Foot		\$	\$
Single White Line	Linear Foot		\$	\$
Double Yellow Line	Linear Foot		\$	\$
Single Yellow Line	Linear Foot		\$	\$
Single Yellow & Broken Yellow Lines	Linear Foot		\$	\$
24" Yellow Gore Marks	Linear Foot		\$	\$
6" Crosswalks	Linear Foot	1500 L.F.	\$ 2.45	\$ 3675.00
24" Crosswalks	Linear Foot	1200 L.F.	\$ 8.00	\$ 9600.00
Arrows	Per Unit	92	\$ 125.00	\$ 11,500.00
Onlys	Per Unit	107	\$ 165.00	\$ 17,655.00
24" Stop Bar	Linear Foot	1400 L.F.	\$ 8.00	\$ 11,200.00
Stop Legends	Per Unit		\$	\$
1' Vascar Lines	Linear Foot		\$	\$
Parking Lot Spaces	Linear Foot		\$	\$
Handicap Spaces	Per Unit	10	\$ 250.00	\$ 2500.00

<b>TOTAL</b>	<b>\$ 56,130.00</b>
--------------	---------------------

**Attachment #3**  
**Schedule of Prices - Totals**

Attachment #1 Painted Markings Total	\$ 167,254.95
Attachment #2 Thermoplastic Markings Total	\$ 56,130.00

Grand  
Total

\$ 223,384.95

# MEMO

Date: May 28, 2026

From: Derek Davis, Township Manager

To: Board of Supervisors

Re: Shredding Resolution 2026-08

---

As allowed by the Commonwealth, the township does dispose of records in a manner pursuant with the guidelines set forth by the Pennsylvania Historical and Museum Commission (PHMC). This resolution is one that we pass every year reiterating the fact that the records we dispose of are allowed and that East Goshen follows the letter of the law.

The list of the specific records to be disposed of is attached along with the resolution.

**DRAFT MOTION:** Mr. Chair, I move we pass Resolution 2026-08, authorizing disposal of East Goshen Township records in accordance with Pennsylvania Historical and Museum Commission guidelines.

**2026 Shredding:**

2018 Park & Recreation

2019 Accounts Payable Boxes

- a. Accounts Payable 2019 A-Com
- b. Accounts Payable 2019 Con-G
- c. Accounts Payable 2019 H-M
- d. Accounts Payable 2019 N-P
- e. Accounts Payable 2019 R-Z

2019 Bank Reconciliations

2019 Liquid Fuels

2019 All Treasurer's Reports

Utility Bills

- a. 8/2/2018-1/2/2019
- b. 1/3/2019-6/5/2019
- c. 6/6/2019-12/31/2019
- d. 8/28/2013- 12/31/2013 Batch 7636-8089, Box also includes 2013 Tax Batch Receipts 3/27/2013-12/31/13 Batch 4594-5063

2019 Cash Receipts Registers – Batch 15106 1/4/19 through Batch 15599 5/20/19

2019 Cash Receipts Registers – Batch 15600 5/21/19 through Batch 16102 10/30/19

2019 Cash Receipts Registers – Batch 16103 10/31/19 through Batch 16271 1/2/20

2019 Month End Reports- Utility and 2019 Quarterly Invoice Registers – Utility, 2019 Utility Certs

**EAST GOSHEN TOWNSHIP  
CHESTER COUNTY, PENNSYLVANIA**

**RESOLUTION 2026-08**

**A RESOLUTION AUTHORIZING DISPOSAL OF  
EAST GOSHEN TOWNSHIP RECORDS**

**WHEREAS**, the general guidelines issued for the Pennsylvania Local Government Records Committee by the Pennsylvania Historical and Museum Commission, Bureau of the Pennsylvania State Archives (“the State Guidelines”) require that most Township records be retained for a minimum of seven years;

**WHEREAS**, certain documents must be retained for more than seven years, including personnel files (105 years from employee’s date of birth); minute books (permanently); loan and bond documents (7 years after the loan or bond is paid off); and planning, zoning and building documents (generally permanently);

**WHEREAS**, the East Goshen Township (“the Township”) record retention policy is consistent with the State Guidelines;

**BE IT RESOLVED THAT** this year, the Township will dispose of (shred) records that can be disposed pursuant to the State Guidelines.

**RESOLVED AND ADOPTED**, this 2<sup>nd</sup> day of June 2026.

ATTEST:

**EAST GOSHEN TOWNSHIP  
BOARD OF SUPERVISORS**

\_\_\_\_\_  
Derek J. Davis, Secretary

\_\_\_\_\_  
Cody Bright, Chair

\_\_\_\_\_  
Barbara Emery, Vice Chair

\_\_\_\_\_  
Ann Duffield, Member

\_\_\_\_\_  
Peter Hicks, Member

\_\_\_\_\_  
Larry Massaro, Member

# MEMO

Date: May 28, 2026

From: Derek Davis, Township Manager

To: Board of Supervisors

Re: Watershed Restoration Grant – Resolution 2026-09

---

East Goshen continues to move forward with pond restoration projects throughout the township. The next one on the list will be the Tanglewood Drive pond in the Hershey's Mill Estates section of East Goshen.

We continue to work through some permitting issues with DEP (fairly minor) but, in the meantime, Pennoni brought to our attention a grant that may be applicable to the project. We are seeking approval to apply for the grant. The project is scheduled anyway so this would be an expense we anticipate regardless if we receive the grant or not.

**DRAFT MOTION:** Mr. Chair, I move we approve Resolution 2026-09, authorizing the Township Engineer and the Township Manager to apply for the *Watershed Restoration Protection* program grant in the amount of \$238,182 with East Goshen anticipating a \$42,033 match.

May 31, 2026

PA Department of Community and Economic Development  
Office of Business Financing – CFA Programs Division  
Watershed Restoration and Protection Program  
Commonwealth Keystone Building  
400 North Street, 4<sup>th</sup> Floor  
Harrisburg, PA 17120-0225

**Re: East Goshen Township Tanglewood Pond Dredging  
PA Department of Community and Economic Development  
Watershed Restoration Protection Program  
Commitment Letter  
East Goshen Township, Chester County, PA**

To Whom it May Concern:

East Goshen Township is providing a required 15% match of **\$42,033** for the referenced project.

**Township General Funds** will be used to provide the entire **\$42,033**. Funds will be available at the date of the award.

If you have any questions or need more information on this project, please feel free to contact me.

Sincerely,

Derek Davis  
Township Manager

May 28, 2026

PA Department of Community and Economic Development  
Center for Business Financing – Grants Division  
Commonwealth Keystone Building  
400 North Street, 4<sup>th</sup> Floor  
Harrisburg, PA 17120-0225

**Re: PA Department of Community and Economic Development  
Watershed Restoration and Protection Program  
Comprehensive Planning Letter  
East Goshen Township Tanglewood Pond Dredging**

To Whom it May Concern:

The East Goshen Township Tanglewood Pond Dredging project is consistent with the East Goshen Township Comprehensive Plan, completed in 2015. The East Goshen Township Comprehensive Plan outlines a few specific goals in reference to stormwater management. The plan mentions the following:

- **Section 9 – Community Facilities and Service Plan:** Goal No. 9.1 Maintain and expand the open space, recreation, and trails.
- **Section 10 – Utilities Plan:** Goal No. 10.5 Maintain effective stormwater management.
- **Section 11 – Natural Resources Protection Plan:** Goal No. 11.1 Protecting the riparian areas along Ridley and Chester Creeks and their tributaries.
- **Section 11 – Natural Resources Protection Plan:** Goal No. 11.10 Improving and enhancing green infrastructure.

Additionally, East Goshen Township conducted a Pond Study in 2018, prepared by Natural Lands, to assess the overall functionality of the ponds and provide recommendations to help maintain the ponds as basic stormwater management structures. This proposed project was specially outlined in the study.

The goal of this project is to dredge an existing pond that has filled with sediment over the years, reducing the pond's capacity to hold stormwater runoff. The project will help the township achieve the comprehensive plan goals of maintaining Township open space, maintain effective stormwater management, improve and enhance green infrastructure, and protect Ridley and Chester Creek and their tributaries.

Should you have any questions or comments, please contact the undersigned.

Sincerely,

John Stipe  
Chair, East Goshen Township Planning Commission



Project Name: Tanglewood Pond Dredging  
 Location: East Goshen Township  
 Project Number: EGOST00038.03  
 Date: May-26

East Goshen Township  
 ENGINEERS OPINION OF PROBABLE COSTS

Item	Description	Quantity	Unit	Unit Price	Amount
1	Mobilization	1	LS	\$ 10,000	\$ 10,000
2	Erosion and Sediment Controls	1	LS	\$ 17,000	\$ 17,000
3	Dredging	1	LS	\$ 125,000	\$ 125,000
4	Forebay Installation	1	LS	\$ 8,000	\$ 8,000
5	Rock Energy Dissipators	1	LS	\$ 7,000	\$ 7,000
6	Respreading of Material	1	LS	\$ 35,000	\$ 35,000
7	Landscaping	1	LS	\$ 7,500	\$ 7,500
8	Restoration and Seeding	1	LS	\$ 5,000	\$ 5,000
9	Permitting	1	LS	\$ 25,000	\$ 25,000
<b>Subtotal:</b>					<b>\$ 239,500</b>

Contingency (5%)	\$ 11,975
Administrative (2%)	\$ 4,790
Engineering/Inspection (10%)	\$ 23,950

<b>Total</b>	<b>\$ 280,215</b>
--------------	-------------------

East Goshen Township  
 GRANT FUNDING BREAKDOWN

Item	Funding	Amount	Percentage	Match Type
1	Funding Request	\$ 238,182	85%	
2	East Goshen Township Match	\$ 42,033	15%	Cash Match
<b>Total</b>		<b>\$ 280,215</b>	<b>100%</b>	

## Appendix II – Authorized Official Resolution

2026-09

Be it RESOLVED, that the Township of East Goshen (Name of Applicant) of Chester County (Name of County) hereby request a Watershed Restoration and Protection Program (WRPP) grant of \$ 238,182 from the Commonwealth Financing Authority of the Commonwealth of Pennsylvania to be used for Tanglewood Pond Dredging.

Be it FURTHER RESOLVED, that the Applicant does hereby designate Cody Bright, Chair, Board of Supervisors (Name and Title) and Derek Davis, Township Manager (Name and Title) as the official(s) to execute all documents and agreements between the Township of East Goshen (Name of Applicant) and the Commonwealth Financing Authority to facilitate and assist in obtaining the requested grant.

I, \_\_\_\_\_, duly qualified Secretary of the Township of East Goshen (Name of Applicant), Chester County (Name of County), PA, hereby certify that the forgoing is a true and correct copy of a Resolution duly adopted by a majority vote of the Board of Supervisors (Governing Body) at a regular meeting held June 2<sup>nd</sup>, 2026 (Date) and said Resolution has been recorded in the Minutes of the Township of East Goshen (Applicant) and remains in effect as of this date.

IN WITNESS THEREOF, I affix my hand and attach the seal of the Township of East Goshen (Applicant), this 2<sup>nd</sup> day of June, 2026.

East Goshen Township

\_\_\_\_\_  
Name of Applicant

Chester

\_\_\_\_\_  
County

\_\_\_\_\_  
Secretary

# MEMO

Date: May 28, 2026

From: Derek Davis, Township Manager

To: Board of Supervisors

Re: Resolution 2026-10

---

During the reversal of the eminent domain proceedings with regard to the Hicks Farm in 2021, filing mistakes were made in terms of the legal documents. Tonight's resolution, and accompanying documents, are simply an effort to correct the mistake and have the correct, amended version filed.

**DRAFT MOTION:** I move we pass Resolution 2026-10, filing Exhibit "A" and Exhibit "B" with the county Recorder of Deeds in order to amend the *Notice of Agreement* regarding the *Relinquishment of Title* for both properties.

**THE BOARD OF SUPERVISORS  
EAST GOSHEN TOWNSHIP  
CHESTER COUNTY, PENNSYLVANIA**

**RESOLUTION NO. 2026 - 10**

**A RESOLUTION OF THE BOARD OF SUPERVISORS OF EAST  
GOSHEN TOWNSHIP, CHESTER COUNTY, PENNSYLVANIA,  
APPROVING THE AMENDED NOTICES OF AGREEMENT  
REGARDING RELINQUISHMENT OF TITLE AND AUTHORIZING THE  
TOWNSHIP SOLICITOR TO RECORD SUCH AMENDED NOTICES OF  
AGREEMENT.**

**WHEREAS**, East Goshen Township is a duly organized Pennsylvania Second Class Township located in Chester County, Pennsylvania (the “Township”); and

**WHEREAS**, pursuant to the Pennsylvania Eminent Domain Code, the Township has the authority to condemn; and

**WHEREAS**, on or around June 25, 2021, the Township filed a Declaration of Taking for certain permanent and temporary easement interests on a property in East Goshen Township, owned by William I. Hicks identified as Chester County Tax Parcel No. 53-3-1.8 (the “William Hicks Property”); and

**WHEREAS**, also on or around June 25, 2021, the Township filed a Declaration of Taking for certain permanent and temporary easement interests on a property in East Goshen Township owned by Peter M. Hicks and Philip Hicks identified as Chester County Tax Parcel No. 53-3-1.9 (the “Peter and Philip Hicks Property”).

**WHEREAS**, on or around July 18, 2022, the Township and the owners of the William Hicks Property and the Peter and Philip Hicks Property (collectively the “Properties”) entered into a Settlement Agreement and General Release for each Property, which revested and reinstated the owners’ rights, responsibilities, mortgages and other liens existing at the time of execution of the Settlement Agreement; and

**WHEREAS**, on July 22, 2022, Notices of Agreement Regarding Relinquishment of Title were filed by the Township with the Chester County Recorder of Deeds for both Properties; and

**WHEREAS**, each of the Notices of Agreement Regarding Relinquishment of Title included several errors and/or missing pages found in the exhibits; and

**WHEREAS**, the Township and the owners of each of the Properties wish to correct these errors and file corrected Notices of Agreement Regarding Relinquishment of Title; and

**WHEREAS**, Amended Notices of Agreement Regarding Relinquishment of Title for the Properties are attached hereto as Exhibit “A” and Exhibit “B”.

**WHEREAS**, the Board of Supervisors approves the recordation of the Amended Notices of Agreement Regarding Relinquishment of Title.

**NOW, THEREFORE, BE IT RESOLVED** and **ADOPTED** by the Board of Supervisors of East Goshen Township, Chester County, as follows:

**Section 1.** In order to correct the errors included in the previously filing, the Board of Supervisors hereby approves filing the Amended Notices of Agreement Regarding Relinquishment of Title for the William Hicks Property and Peter and Philip Hicks Property. The Amended Notices of Agreement Regarding Relinquishment of Title shall supersede the previously filed Notices of Agreement.

**Section 2.** The Board of Supervisors hereby directs and authorizes the Solicitor of East Goshen Township to record the two Amended Notices of Agreement Regarding Relinquishment of Title attached hereto as Exhibit "A" and Exhibit "B" with the Chester County Recorder of Deeds.

**Section 3.** This Resolution shall be effective immediately.

**RESOLVED THIS 2<sup>nd</sup> DAY OF June, 2026**

**BOARD OF SUPERVISORS  
EAST GOSHEN TOWNSHIP**

\_\_\_\_\_  
Cody Bright, Chair

\_\_\_\_\_  
Barbara Emery, Vice Chair

\_\_\_\_\_  
Peter Hicks

\_\_\_\_\_  
Ann Duffield

\_\_\_\_\_  
Larry Massaro

**ATTEST:**

\_\_\_\_\_  
Derek J. Davis, Manager

# **Exhibit A**

**RETURN TO:**

Mark P. Thompson, Esq.  
LAMB MCERLANE PC  
24 E. Market Street  
P.O. Box 565  
West Chester, PA 19381-0565

UPI No. 53-3-1.8 (Part of)

**AMENDED NOTICE OF AGREEMENT REGARDING RELINQUISHMENT OF TITLE**

*(THIS AMENDED NOTICE OF AGREEMENT IS BEING RECORDED TO CORRECT AN ERROR  
IN THE RELINQUISHMENT PACKAGE FILED WITH THE RECORDER OF DEED WHICH INCLUDED A  
MISSING EXHIBIT AND INCORRECT DOCUMENTS.)*

THIS AMENDED NOTICE OF AGREEMENT REGARDING RELINQUISHMENT OF TITLE is made this \_\_\_\_ day of \_\_\_\_\_, 2026 by and between WILLIAM I. HICKS ("Condemnee"), an adult individual, 1325 Paoli Pike, West Chester, County of Chester and Commonwealth of Pennsylvania and the TOWNSHIP OF EAST GOSHEN, 1580 Paoli Pike, West Chester, County of Chester and Commonwealth of Pennsylvania ("Condemnor").

**BACKGROUND**

A. On or around June 15, 2021, Condemnor began the process of condemning part of the property located at 1325 Paoli Pike, West Chester, Pennsylvania 19381, UPI No. 53-3-1.8 (the "Property"), owned by Condemnee, by adopting Resolution No. 2021-201.

B. On or around June 25, 2021, Condemnor filed a Declaration of Taking with the Chester County Court of Common Pleas.

C. On or around July 18, 2022, Condemnor and Condemnee entered into a Settlement Agreement and General Release.

D. The Settlement Agreement and General Release revested and reinstated Condemnee's ownership of the Property and Condemnee's rights, responsibilities, mortgages and other liens existing at the time of the execution of the Settlement Agreement and General Release, which were not thereafter discharged.

E. On July 22, 2022, a Notice of Agreement Regarding Relinquishment of Title was filed with the Chester County Recorder of Deeds Office at Book 10916, Page 569.

F. Subsequent to filing several errors were found in the exhibits attached to the Notice of Agreement regarding Relinquishment of Title. The parties now wish to correct the error in the previous Agreement and confirm Condemnee's title to the Property as originally intended.

G. The parties hereby attach hereto Exhibit "A" as the corrected Notice of Agreement Regarding Relinquishment of Title.

H. The Notice of Agreement Regarding Relinquishment of Title, filed at Book 10916, Page 569 is superseded by the Exhibit "A" attached hereto.

IN WITNESS WHEREOF, Condemnor and Condemnee have executed this Amended Notice of Agreement Regarding Relinquishment of Title the day and year first above written.  
Signed, sealed and delivered in the presence of:

CONDEMNEE,

By: \_\_\_\_\_  
WILLIAM I. HICKS

CONDEMNOR,  
TOWNSHIP OF EAST GOSHEN  
BOARD OF SUPERVISORS

By: \_\_\_\_\_  
, Chair





## **Exhibit “A”**

*Amended Notice of Agreement Regarding Relinquishment of Title*

WILLIAM  
CORRECTED

Prepared by, and after recording please return to:



Michael S. Gill, Esquire  
Buckley, Brion, McGuire & Morris LLP  
118 West Market Street  
West Chester, Pennsylvania 19382  
610.436.4400

Part of : UPI No. 53-3-1.8 ✓

**NOTICE OF AGREEMENT REGARDING RELINQUISHMENT OF TITLE**

IN RE  
CONDEMNATION BY  
TOWNSHIP OF EAST GOSHEN  
OF REAL PROPERTY  
LOCATED IN THE  
TOWNSHIP OF EAST GOSHEN,  
COUNTY OF CHESTER,  
COMMONWEALTH OF PENNSYLVANIA,  
FOR THE PURPOSE OF THAT CERTAIN  
PUBLIC RECREATION PROJECT KNOWN AS  
PAOLI PIKE TRAIL  
(PART OF TAX MAP PARCEL NO. 53-3-1.8)

: COURT OF COMMON PLEAS  
: CHESTER COUNTY,  
: PENNSYLVANIA  
:  
: CIVIL ACTION NO. 2021-04834-RC  
:  
: IN REM  
: EMINENT DOMAIN

FEE TITLE HOLDER: WILLIAM I. HICKS, AN ADULT INDIVIDUAL

This NOTICE OF AGREEMENT REGARDING RELINQUISHMENT OF TITLE  
is executed this 18<sup>th</sup> day of July, 2022, by Condemnor Township of East Goshen ("Condemnor")  
and Condemnee William I. Hicks ("Condemnee").

Condemnor and Condemnee are parties to that certain Settlement Agreement and General  
Release dated July 18, 2022, and regarding the above-captioned matter (the "Settlement  
Agreement").

Pursuant to the Settlement Agreement, and as mandated pursuant to Section 308.(e) of the  
Pennsylvania Eminent Domain Code, 26 Pa.C.S.A. § 308.(e), Condemnor and Condemnee hereby  
provide notice to the world entire that all right, title, and interest which passed to Condemnor upon

DOC # 11936406 07/22/2022 11:23 AM  
Receipt #: 22-31730  
Rec Fee: \$98.50  
Chester County, Recorder of Deeds

11936406 B: 10916 P: 569 NOT  
07/22/2022 11:23 AM Page 1 of 32  
BUCKLEY BRION



Condemnor's filing of the Declaration of Taking (a copy of which is attached hereto as Exhibit A) in this matter is, and for all intents and purposes whatsoever shall be deemed to be, reverted in Condemnee, and all mortgages and other liens existing as of the date of such filing which were not thereafter discharges are, and for all intents and purposes whatsoever shall be deemed to be, reinstated.

IN WITNESS WHEREOF, Condemnor and Condemnee have executed this Notice of Agreement Regarding Relinquishment of Title the day and year first above written.

THE TOWNSHIP OF EAST GOSHEN,  
a Township of the Second Class

By: its Board of Supervisors,  
the duly elected and constituted  
governing body thereof

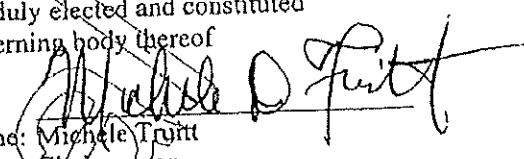
By:   
Name: Michele Trutt  
Title: Chairwoman

Commonwealth of Pennsylvania - Notary Seal  
Derek J. Davis, Notary Public  
Chester County  
My commission expires November 29, 2024  
Commission number 1273276  
Member, Pennsylvania Association of Notaries

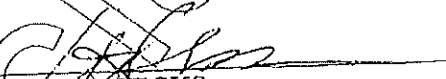
  
WILLIAM HICKS

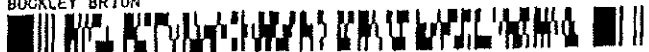

ATTORNEY ACKNOWLEDGMENT

COMMONWEALTH OF PENNSYLVANIA :  
COUNTY OF CHESTER :  
: ss  
:

The foregoing Notice of Agreement Regarding Relinquishment of Title was acknowledged before me on July 18, 2022 by Michael S. Gill, Esquire, Supreme Court Identification Number 86140. As a member of the Bar of the Pennsylvania Supreme Court, he certified that he was personally present when Michele Truitt executed the Notice of Agreement Regarding Relinquishment of Title as Chairwoman of the Board of Supervisors of East Goshen Township and that she in such capacity executed the same for the purposes contained therein.

IN WITNESS WHEREOF, I hereunto set my hand and official seal.

*Robyn A Cahill*  
Notary Public

My Commission Expires:

Commonwealth of Pennsylvania - Notary Seal  
Robyn A. Cahill, Notary Public  
Chester County  
My commission expires November 18, 2025  
Commission number 1021755  
Member, Pennsylvania Association of Notaries



# EXHIBIT A

11936406 B: 10916 P: 572 NOT  
07/22/2022 11:23 AM Page 4 of 32  
BUCKLEY BRION

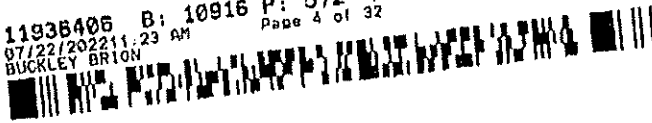

BUCKLEY, BRION,  
McGUIRE & MORRIS LLP  
By: Kristin S. Camp, Esquire  
Attorney I.D. No. 74593  
By: Michael S. Gill, Esquire  
Attorney I.D. No. 86140  
118 West Market Street  
West Chester, Pennsylvania 19382  
610.436.4400

ATTORNEYS FOR CONDEMNOR  
TOWNSHIP OF EAST GOSHEN

IN RE  
CONDEMNATION BY  
TOWNSHIP OF EAST GOSHEN  
OF REAL PROPERTY  
LOCATED IN THE  
TOWNSHIP OF EAST GOSHEN,  
COUNTY OF CHESTER,  
COMMONWEALTH OF PENNSYLVANIA,  
FOR THE PURPOSE OF THAT CERTAIN  
PUBLIC RECREATION PROJECT KNOWN AS  
PAOLI PIKE TRAIL  
(PART OF TAX MAP PARCEL NO. 53-3-1.8)

COURT OF COMMON PLEAS  
CHESTER COUNTY,  
PENNSYLVANIA  
CIVIL ACTION NO. 2021-\_\_\_\_\_

IN REM  
EMINENT DOMAIN

FEE TITLE HOLDER: WILLIAM I. HICKS, AN ADULT INDIVIDUAL

DECLARATION OF TAKING

The Township of East Goshen (the "Condemnor"), by and through its undersigned counsel, Kristin S. Camp, Esquire, Michael S. Gill, Esquire, and Buckley, Brion, McGuire & Morris LLP, files this Declaration of Taking as provided for in the Pennsylvania Eminent Domain Code of 2006, Act of May 4, 2006, P.L. 112, No. 34, § 1 (the "Code"), 26 PA.C.S.A § 302, and respectfully declares as follows:

1. Condemnor is the Township of East Goshen, a township of the second class organized and existing under and pursuant to the laws of the Commonwealth of Pennsylvania and having an address at 1580 Paoli Pike, West Chester, Pennsylvania 19380-6199.
2. Condemnee is William I. Hicks, an adult individual.



3. The address for Condemnee as determined from the records of the Board of Assessment of the County of Chester is: Post Office Box No. 3113, West Chester, Pennsylvania 19381.

4. Condemnor is authorized and empowered by Section 2201 of the Pennsylvania Second Class Township Code, 53 P.S. § 67201 to acquire "lands . . . by the exercise of the right of eminent domain for recreational purposes."

5. In order to complete the public recreation project known as the Paoli Pike Trail, Condemnor requires certain permanent and temporary easement interests and rights-of-way or fee-simple ownership in, on, over, to, and through certain portions of real property *situate* within Condemnor's jurisdictional limits and as more fully depicted on Exhibit A and as more fully described by metes and bounds (as to the required permanent easement and the required right-of-way) on Exhibit B, each attached hereto and incorporated herein by reference (the "Necessary Real Property Interests").

6. This Declaration of Taking was authorized by Resolution No. 2021-201 which the Board of Supervisors of Condemnor adopted on June 15, 2021. A copy of said Resolution is attached hereto as Exhibit C and is incorporated herein by reference. The record thereof may be examined at Condemnor's office at 1580 Paoli Pike, West Chester, Pennsylvania 19380-6199.

7. The purpose of the condemnation is to acquire property in connection with the construction and operation of that certain public recreation project known as Paoli Pike Trail.

8. The Necessary Real Property Interests are *situate* in the Township of East Goshen, County of Chester, Commonwealth of Pennsylvania. A plan of the Necessary Real Property Interests, sufficient for the identification thereof, is attached hereto as Exhibit A and is incorporated herein by reference. Metes and bounds descriptions of the required permanent

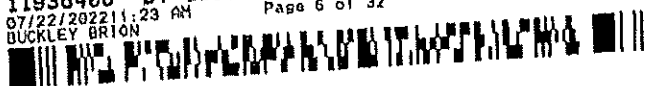

easement and the required right-of-way components of the Necessary Real Property Interests sufficient for their identification, are as set forth at Exhibit B attached hereto and incorporated herein by reference.

9. On the same day on which Condemnor files this Declaration of Taking with the Office of the Prothonotary, Condemnor is filing with the Office of the Recorder of Deeds in and for Chester County a plan showing the Necessary Real Property Interests, all in accordance with Section 304 of the Code, 26 PA. C.S.A. § 304.

10. The nature of the title in and to the property hereby condemned is (A) 12,360 square feet, more or less, of required permanent sidewalk easement, (B) 12,346 square feet, more or less, of required temporary construction easement (the "Temporary Construction Easement"), and (C) 15,892 square feet, more or less, of required permanent fee-simple right-of-way. The term of the Temporary Construction Easement will commence upon the date of Condemnor's entry onto the Necessary Real Property Interests and will endure for a period of thirty (30) months from that date. In the event that there are recoverable subsurface minerals (including gas and oil) within the area of the Necessary Real Property Interests, the subsurface mineral rights (including rights to gas and oil) in that area are hereby excepted and reserved from this condemnation; provided, however, that the right of later and adjacent support of the surface hereby condemned and any improvements now or hereafter erected thereon are included within the scope of this condemnation. Access for the removal of subsurface materials (including gas and oil) must be obtained from beyond the Necessary Real Property Interests, unless expressly permitted otherwise by Condemnor.

11. A plan showing the Necessary Real Property Interests may be inspected at the office of Condemnor's counsel, Buckley, Brion, McGuire & Morris LLP, 118 West Market Street, Suite 300, West Chester, Pennsylvania 19382, during regular business hours.



12. Just compensation for the condemnation of the Necessary Real Property Interests is secured by the power of taxation of Condemnor, whereupon the funds raised, or lawful to be so raised, are deemed pledged and made security for the payment of the damages as shall be determined by law.

Date: June 25, 2021

Respectfully submitted,

BUCKLEY, BRION, MCGUIRE & MORRIS LLP

By: Kristin S. Camp  
Kristin S. Camp, Esquire

By: Michael S. Gill  
Michael S. Gill, Esquire

Attorneys for Condemnor  
Township of East Goshen



CERTIFICATION OF COMPLIANCE

I hereby certify that this filing complies with the provisions of the *Public Access Policy of the Unified Judicial System of Pennsylvania: Case Records of the Appellate and Trial Courts* that require filing confidential information and documents differently than non-confidential information and documents.

Dated: June 25, 2021

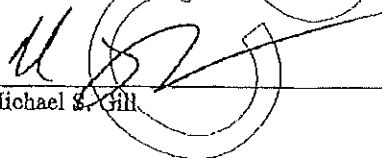
  
\_\_\_\_\_  
Michael S. Gill



**EXHIBIT A**

Unofficial Copy

11936406 B: 10916 P: 578 NOT  
07/22/2022 11:23 AM Page 10 of 32  
BUCKLEY BRION

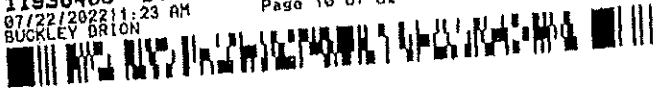

NOTES:  
 1) THE LEGAL RIGHT-OF-WAY WIDTH ON PAULI PIKE SR 2014 FROM STA. 97+00 TO STA. 104+23.46 IS VARIABLE FROM 40 FEET TO 84 FEET BASED ON DRAWINGS FOR ACCEPTING DEDICATION OF RIGHT-OF-WAY FOR STATE ROUTE 2014 SECTION L-27-R/W DATED MAY 13, 1992 AND RECORDED IN THE CHESTER COUNTY RECORDER OF DEEDS IN PLAN BOOK 89 PAGE 7 ON JULY 14, 1992.

2) [REDACTED] AN EASEMENT TO USE THE LAND AS NECESSARY DURING CONSTRUCTION OF THE PROJECT. THE EASEMENT IS REQUIRED ONLY UNTIL THE CONSTRUCTION OF WORK INDICATED BY THE PLAN IS COMPLETED, UNLESS SOONER RELINQUISHED IN WRITING BY EAST GOSHEN TOWNSHIP.







3) [REDACTED] AN EASEMENT FOR THE CONSTRUCTION, INSPECTION, MAINTENANCE, REPAIR, RECONSTRUCTION AND ALTERATION OF A SIDEWALK. THE EASEMENT SHALL NOT PREVENT THE PROPERTY OWNER FROM MAKING ANY LEGAL USE OF THE AREA WHICH IS NOT DETRIMENTAL TO ITS USE FOR SIDEWALK PURPOSES.

4) THE BEARING SYSTEM IS BASED ON THE PROJECT DATUM: PENNSYLVANIA STATE PLANE COORDINATE SYSTEM (NAD 83).

TOTAL AREA OF [REDACTED]  
 = 12360 SF, 0.284 AC

TOTAL AREA OF TEMPORARY CONSTRUCTION EASEMENT  
 = 12346 SF, 0.283 AC

REQUIRED SIDEWALK EASEMENT LINE TABLE		
LINE	BEARING	DISTANCE
L1	N81°48'54"W	17.95'
L2	N80°40'41"E	95.34'
L3	N60°13'21"E	310.00'
L4	N47°48'54"E	31.20'
L5	S29°46'30"E	40.60'
L6	S80°13'21"W	350.01'
L7	N29°46'55"W	10.00'
L8	S81°13'02"W	104.71'

-  REQUIRED SIDEWALK EASEMENT
-  SHARED USE PATH
-  DRIVEWAY ADJUSTMENT
-  REQUIRED RIGHT-OF-WAY
-  ELEVATED SHARED USE PATH STRUCTURE
-  HORSE FARM SPLIT RAIL FENCE
-  SHARED USE PATH SPLIT RAIL FENCE

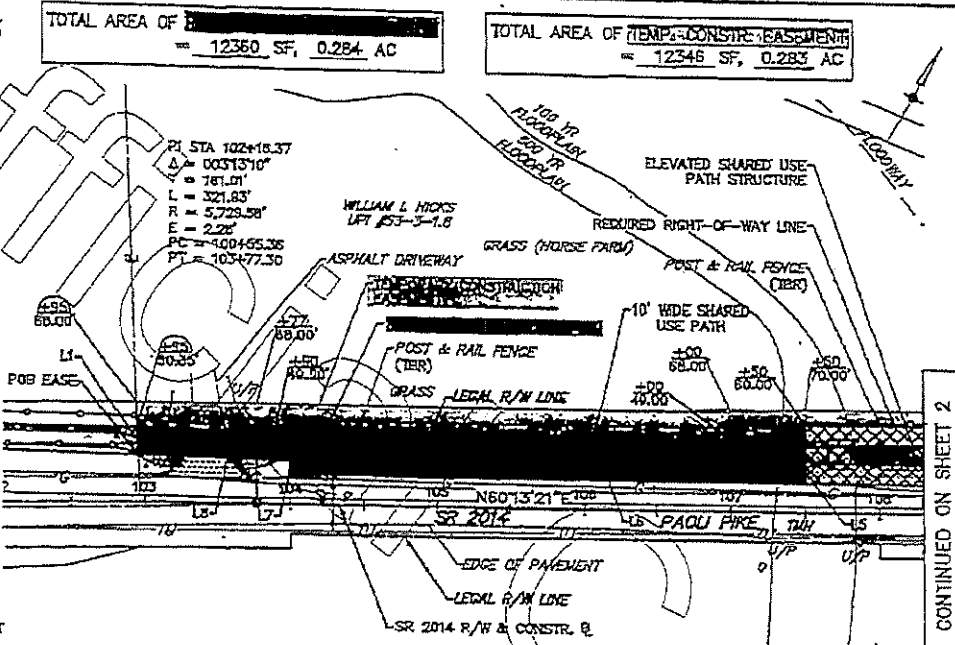

CONTINUED ON SHEET 2

PLAN OF REQUIRED SIDEWALK EASEMENT FOR LANDS OF WILLIAM L. HICKS (UPI #53-3-1.8)  
 SITUATE IN EAST GOSHEN TOWNSHIP, CHESTER COUNTY, PA.



836 SPRINGDALE DRIVE  
 SUITE 200  
 EXTON, PA. 19341  
 TELE: (610)-594-8995  
 FAX: (610)-594-8565



3/3/20  
 JOB #51661720  
 SCALE: 1" = 60'  
 SHEET: 1 of 2

11936406 E: 10916 P: 579 NOT  
 07/22/2021 11:23 AM  
 BUCKLEY BRION  
 Page 11 of 12



# EXHIBIT B

11936406 B: 10916 P: 581 NOT  
07/22/2022 11:23 AM Page 13 of 32  
BUCKLEY BRTON





McMAHON ASSOCIATES, INC.  
 655 Springdale Drive, Suite 200  
 Exton, PA 19341  
 P 610-384-9388 | F 610-384-9566

March 3, 2020

DESCRIPTION OF REQUIRED SIDEWALK BASEMENT  
 FOR LANDS OF WILLIAM I. HICKS  
 (UPI #53-3-1.8)

All that certain required pieces of land situate in the Township of East Goshen, County of Chester, Commonwealth of Pennsylvania. Being part of land further described in an indenture dated the 7th day of January 1987 in Deed Book 591 Page 18 and recorded at West Chester in the Office for the Recorder of Deeds of Chester County, Pennsylvania. Bounded and described in accordance with a plan made by McMahon Associates, Inc., Exton, PA, entitled "PLAN OF REQUIRED SIDEWALK BASEMENT FOR LANDS OF WILLIAM I. HICKS (UPI #53-3-1.8)" dated March 3, 2020, as follows to wit:

Beginning at a point of intersection of the northerly Legal Right-of-Way line of Paoli Pike (SR 2014) (40 feet wide), with the westerly line of Grantors, thence extending the following courses and distances:

- 1) Along the westerly line of Grantors, North 31 degrees 49 minutes 54 seconds West, 17.95 feet to a point.

Thence, through portions of lands of Grantors, the following four courses:

- 2) North 60 degrees 40 minutes 41 seconds East, 95.84 feet to a point,
- 3) North 60 degrees 13 minutes 21 seconds East, 310.00 feet to a point,
- 4) North 47 degrees 48 minutes 54 seconds East, 51.20 feet to a point,
- 5) South 29 degrees 46 minutes 39 seconds East, 40.00 feet to a point in the northerly Legal Right-of-Way line of Paoli Pike.

Thence, along the northerly Legal Right-of-Way line of Paoli Pike, the following three courses:

- 6) South 60 degrees 13 minutes 21 seconds West, 350.01 feet to a point.
- 7) North 29 degrees 46 minutes 58 seconds West, 10.00 feet to a point.
- 8) South 61 degrees 13 minutes 02 seconds West, 104.71 feet to the point and place of beginning.

Containing 12360 square feet, or 0.284 acres.

\\s\proj\161116\Drawn\B\New\Way\Title\Signed\1\53-3-1.8 - W. Hicks\William I Hicks R&B Legal Description.docx





McMAHON ASSOCIATES, INC.  
885 Springdale Drive, Suite 200  
Exton, PA 19341  
610-594-9995 | F 610-594-9563

March 3, 2020

DESCRIPTION OF REQUIRED RIGHT-OF-WAY  
FOR LANDS OF WILLIAM I. HICKS  
(UPI #53-3-1.8)

All that certain required pieces of land situate in the Township of East Goshen, County of Chester, Commonwealth of Pennsylvania, Being part of land further described in an indenture dated the 7th day of January 1987 in Deed Book 591 Page 18 and recorded at West Chester in the Office for the Recorder of Deeds of Chester County, Pennsylvania. Bounded and described in accordance with a plan made by McMahon Associates, Inc., Exton, PA, entitled "PLAN OF REQUIRED RIGHT-OF-WAY FOR LANDS OF WILLIAM I. HICKS (UPI #53-3-1.8)" dated March 3, 2020, as follows to wit:

Beginning at a point in the northerly Legal Right-of-Way line of Paoli Pike (SR 2014) (40 feet wide), said point being distant the following three courses from the point of intersection of the westerly line of Grantor with the northerly Legal Right-of-Way line of Paoli Pike:

- a) Extending along the northerly Legal Right-of-Way line of Paoli Pike, North 61 degrees 13 minutes 02 seconds East, 104.71 feet to a point.
- b) Thence, continuing along the northerly Legal Right-of-Way line of Paoli Pike, South 29 degrees 46 minutes 58 seconds East, 10.00 feet to a point.
- c) Extending along the northerly Legal Right-of-Way line of Paoli Pike, North 60 degrees 13 minutes 21 seconds East, 350.01 feet to the point and place of beginning.

Thence, through portions of lands of Grantors, the following four courses:

- 1) North 29 degrees 46 minutes 59 seconds West, 40.00 feet to a point.
- 2) North 60 degrees 13 minutes 21 seconds East, 396.77 feet to a point.
- 3) South 31 degrees 17 minutes 42 seconds East, 40.01 feet to a point in the northerly Legal Right-of-Way line at Paoli Pike.
- 4) Thence, along the northerly Legal Right-of-Way line of Paoli Pike, South 60 degrees 13 minutes 21 seconds West, 397.83 feet to the point and place of beginning.

Containing 15892 square feet, or 0.365 acres.

(UPI #53-3-1.8) (Legal Right-of-Way) (Project #53-3-1.8 - W. Hicks) (William I. Hicks L&O) (Legal) (Deed) (to subor)

Engineering | Pl

11936406 B: 10916 P: 583 NOT  
07/22/2022 11:23 AM Page 15 of 32  
BUCKLEY BRION

oclater.com



EXHIBIT C

Unofficial Copy

11935406 B: 10916 P: 584 NOT  
07/22/2022 11:23 AM Page 16 of 32  
BUCKLEY BRION

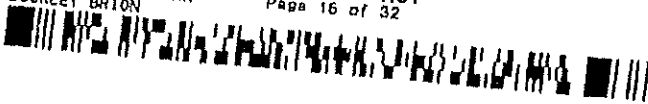

EAST GOSHEN TOWNSHIP  
CHESTER COUNTY, PENNSYLVANIA

RESOLUTION NO. 2021-201

RESOLUTION OF THE BOARD OF SUPERVISORS OF EAST GOSHEN TOWNSHIP AUTHORIZING THE ACQUISITION OF REAL PROPERTY INTERESTS SITUATE IN THE TOWNSHIP OF EAST GOSHEN, CHESTER COUNTY, PENNSYLVANIA BY PURCHASE OR CONDEMNATION FOR THE PURPOSE OF THE PUBLIC RECREATION PROJECT KNOWN AS THE PAOLI PIKE TRAIL.

WHEREAS, East Goshen Township (the "Township") is engaged in consultation and cooperation with the Commonwealth of Pennsylvania Department of Transportation with regard to that certain public recreation project known as the Paoli Pike Trail; and

WHEREAS, the Board of Supervisors of the Township (the "Board") is authorized and empowered pursuant to applicable law (including, without limitation, Section 2201 of the Pennsylvania Second Class Township Code, 53 P.S. § 57201), to acquire real property interests necessary for, and in furtherance of completion of, the Paoli Pike Trail; and

WHEREAS, in order to facilitate the Paoli Pike Trail, the Township requires certain permanent and temporary easement interests and rights-of-way or fee-simple ownership in, on, over, to, and through certain portions of real property *situate* within the Township and as more fully depicted on Exhibit A and as more fully described by metes and bounds (as to the required permanent easement and the required right-of-way) on Exhibit B, each attached hereto and incorporated herein by reference (the "Necessary Real Property Interests"); and

WHEREAS, the Necessary Real Property Interests include a permanent easement having an area measuring 12,360 square feet, more or less, identified on Exhibit A as "Required Sidewalk Easement" and a temporary construction easement having an area measuring 12,346 square feet, more or less, identified on Exhibit A as "Temporary Construction Easement," and right-of-way having an area measuring 15,892 square feet, more or less, identified on Exhibit A as "Required Right-of-Way;" and

WHEREAS, the Necessary Real Property Interests are, as of the date of this Resolution, part of the real property identified as Chester County Tax Map Parcel No. 53-3-1,8.

NOW, THEREFORE,

BE IT RESOLVED by the Board, and it is hereby resolved by authority of the same, that the acquisition of the Necessary Real Property Interests by purchase or condemnation according to law is authorized for, and in connection with, the public recreation project known as the Paoli Pike Trail; and



BE IT FURTHER RESOLVED by the Board, and it is hereby resolved by authority of the same, that the Necessary Real Property Interests for the public recreation project known as Paoli Pike Trail shall be acquired by the Township by purchase or condemnation under the provisions of the Acts of Assembly as more fully set forth in the Resolution; and

BE IT FURTHER RESOLVED by the Board, and it is hereby resolved by authority of the same, that the Township Manager and the Township Solicitor are authorized and directed to take any and all steps which they, in their discretion, deem necessary and proper and in the best interests of the Township to effectuate this Resolution including, without limitation, the filing of one or more Declaration(s) of Taking under and pursuant to the Pennsylvania Eminent Domain Code, 26 Pa.C.S.A. § 101 *et seq.*

ADOPTED by the Board of Supervisors of East Goshen Township this 15<sup>th</sup> day of June, 2021.

ATTEST:

[Signature]  
Louis F. Smith, Secretary

EAST GOSHEN TOWNSHIP  
BOARD OF SUPERVISORS

[Signature]  
David B. Shuey, Chairman

[Signature]  
Michael P. Lynch, Vice-Chairman

[Signature]  
John Hertzog, Member

[Signature]  
Michelle Trullt, Member

[Signature]  
E. Martin Shane, Member



# **EXHIBIT “A”**

U  
P  
C  
O  
P  
Y

11936406 B: 10916 P: 587 NOT  
07/27/2021 11:23 AM  
BUCKET BRION Page 19 of 32

**NOTES:**

- 1) THE LEGAL RIGHT-OF-WAY WIDTH ON PAOLI PIKE SR 2014 FROM STA. 97+00 TO STA. 104+22.46 IS VARIABLE FROM 40 FEET TO 84 FEET BASED ON DRAWINGS FOR ACCEPTING DESIGNATION OF RIGHT-OF-WAY FOR STATE ROUTE 2014 SECTION L-27-R/W DATED MAY 13, 1992 AND RECORDED IN THE CHESTER COUNTY REGISTER OF DEEDS IN PLAN BOOK 89 PAGE 7 ON JULY 14, 1992.
- 2) [REDACTED] CONVEYED AN EASEMENT TO USE THE LAND AS NECESSARY DURING CONSTRUCTION OF THE PROJECT. THE EASEMENT IS REQUIRED ONLY UNTIL THE CONSTRUCTION OR WORK INDICATED BY THE PLAN IS COMPLETED, UNLESS SOONER RELINQUISHED IN WRITING BY EAST GOSHEN TOWNSHIP.
- 3) [REDACTED] AN EASEMENT FOR THE CONSTRUCTION, INSPECTION, MAINTENANCE, REPAIR, RECONSTRUCTION AND ALTERATION OF A SIDEWALK. THE EASEMENT SHALL NOT PREVENT THE PROPERTY OWNER FROM MAKING ANY LEGAL USE OF THE AREA WHICH IS NOT DETRIMENTAL TO ITS USE FOR SIDEWALK PURPOSES.
- 4) THE REARING SYSTEM IS BASED ON THE PROJECT DATUM: PENNSYLVANIA STATE PLANE COORDINATE SYSTEM (NAD 83).

TOTAL AREA OF [REDACTED]  
= 12360 SF, 0.284 AC

TOTAL AREA OF TEMP. CONSTR. EASEMENT  
= 12346 SF, 0.283 AC

**REQUIRED SIDEWALK EASEMENT LINE TABLE**

LINE	BEARING	DISTANCE
L1	N51°49'52"W	17.95'
L2	N60°40'41"E	93.34'
L3	N60°13'21"E	310.00'
L4	N47°48'54"E	51.20'
L5	S20°46'59"E	40.00'
L6	S60°13'21"W	360.01'
L7	N29°46'58"W	70.00'
L8	S81°13'02"W	104.07'

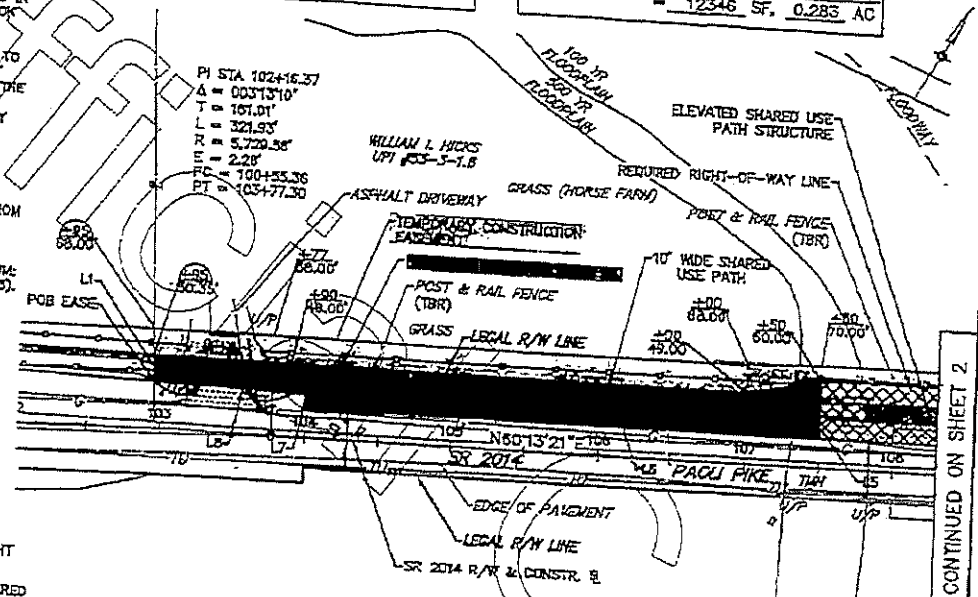
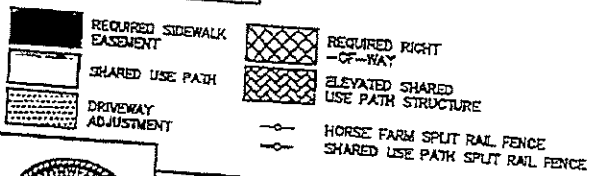

PLAN OF REQUIRED SIDEWALK EASEMENT FOR LANDS OF WILLIAM I. HICKS (UPI #53-3-1.8)  
SITUATE IN EAST GOSHEN TOWNSHIP, CHESTER COUNTY, PA.



835 SPRINGDALE DRIVE  
SUITE 200  
EXTON, PA. 19341  
TEL: (610)-594-9595  
FAX: (610)-594-9565



3/3/20  
JOB #816417.20  
SCALE: 1" = 60'  
SHEET: 1 of 2

CONTINUED ON SHEET 2

U  
h

**NOTES**

1) THE LEGAL RIGHT-OF-WAY WIDTH ON PAOLI PIKE, SR 2014, FORMERLY ROUTE/NO. 143 FROM STA. 1044+23.46 TO STA. 128+94.85 IS 40 FEET BASED ON FINAL DRAWINGS FOR CONSTRUCTION AND CONDEMNATION OF RIGHT-OF-WAY FOR ROUTE 143 SECTION 2, DATED OCTOBER 4, 1945 AND STONED BY THE GOVERNOR EDWARD MARTIN ON APRIL 25, 1946.

2) THE PROPOSED CONSTRUCTION REQUIRES AN EASEMENT TO USE THE LAND AS NECESSARY DURING CONSTRUCTION OF THE PROJECT. THE EASEMENT IS REQUIRED ONLY UNTIL THE CONSTRUCTION OR WORK INDICATED BY THE PLAN IS COMPLETED, UNLESS SOONER RELINQUISHED IN WRITING BY EAST GOSHEN TOWNSHIP.

3) [REDACTED] AN EASEMENT FOR THE CONSTRUCTION, INSPECTION, MAINTENANCE, REPAIR, RECONSTRUCTION AND ALTERATION OF A SIDEWALK. THE EASEMENT SHALL NOT PREVENT THE PROPERTY OWNER FROM MAKING ANY LEGAL USE OF THE AREA WHICH IS NOT DETRIMENTAL TO ITS USE FOR SIDEWALK PURPOSES.







4) THE BEARING SYSTEM IS BASED ON THE PROJECT DATUM: PENNSYLVANIA STATE PLANE COORDINATE SYSTEM (NAD 83).

TOTAL AREA OF REQUIRED RIGHT-OF-WAY  
= 15882 SF, 0.365 AC

TOTAL AREA OF TEMP. CONSTR. EASEMENT  
= 12346 SF, 0.283 AC

REQUIRED RIGHT-OF-WAY LINE TABLE

LINE	BEARING	DISTANCE
L1	N29°48'39"W	40.00'
L2	N60°13'21"E	396.77'
L3	S31°17'42"E	40.01'
L4	S80°13'21"W	397.85'

-  REQUIRED SIDEWALK EASEMENT
-  REQUIRED RIGHT-OF-WAY
-  SHARED USE PATH
-  ELEVATED SHARED USE PATH STRUCTURE
-  SELECTIVE TREE REMOVAL
-  HORSE FARM SPLIT RAIL FENCE
-  SHARED USE PATH SPLIT RAIL FENCE

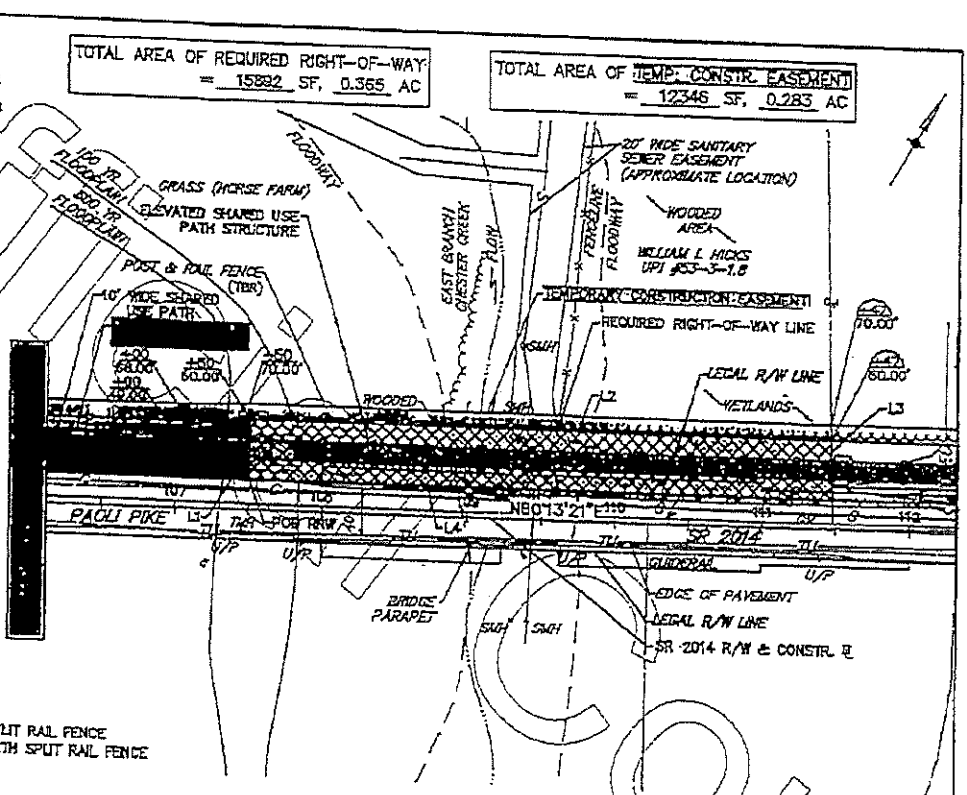

PLAN OF REQUIRED RIGHT-OF-WAY FOR LANDS OF WILLIAM I. HICKS (UPT #53-3-1.8)  
SITUATE IN EAST GOSHEN TOWNSHIP, CHESTER COUNTY, PA.

835 SPRINGDALE DRIVE  
SUITE 200  
EXTON, PA. 19341  
TELE: (610)-594-9995  
FAX: (610)-594-9565



3/3/20  
JOB #61647.20  
SCALE: 1" = 50'  
SHEET: 2 of 2

11936406 B: 10916 P: 588 NOT  
072820201123.RVT  
BUCKLEY BRIDON  
Page 20 of 32

# **EXHIBIT B**



McMAHON ASSOCIATES, INC.  
835 Springdale Drive, Suite 200  
Exton, PA 19341  
p 610-594-9995 | f 610-594-9566

March 3, 2020

DESCRIPTION OF REQUIRED SIDEWALK EASEMENT  
FOR LANDS OF WILLIAM I. HICKS  
(UPI #53-3-1.8)

All that certain required pieces of land situate in the Township of East Goshen, County of Chester, Commonwealth of Pennsylvania, being part of land further described in an indenture dated the 7th day of January 1987 in Deed Book 591 Page 18 and recorded at West Chester in the Office for the Recorder of Deeds of Chester County, Pennsylvania. Bounded and described in accordance with a plan made by McMahon Associates, Inc., Exton, PA, entitled "PLAN OF REQUIRED SIDEWALK EASEMENT FOR LANDS OF WILLIAM I. HICKS (UPI #53-3-1.8)" dated March 3, 2020, as follows to wit:

Beginning at a point of intersection of the northerly Legal Right-of-Way line of Paoli Pike (SR 2014) (40 feet wide), with the westerly line of Grantors, thence extending the following courses and distances:

1) Along the westerly line of Grantors, North 31 degrees 49 minutes 54 seconds West, 17.95 feet to a point.

Thence, through portions of lands of Grantors, the following four courses:

- 2) North 60 degrees 40 minutes 41 seconds East, 95.34 feet to a point,
- 3) North 60 degrees 13 minutes 21 seconds East, 310.00 feet to a point.
- 4) North 47 degrees 48 minutes 54 seconds East, 51.20 feet to a point.
- 5) South 29 degrees 46 minutes 39 seconds East, 40.00 feet to a point in the northerly Legal Right-of-Way line of Paoli Pike.

Thence, along the northerly Legal Right-of-Way line of Paoli Pike, the following three courses:

- 6) South 60 degrees 13 minutes 21 seconds West, 350.01 feet to a point.
- 7) North 29 degrees 46 minutes 58 seconds West, 10.00 feet to a point.
- 8) South 61 degrees 13 minutes 02 seconds West, 104.71 feet to the point and place of beginning.

Containing 12360 square feet, or 0.284 acres.

n:\eng\61641720\Design\Right-of-Way\Task\Segment B\53-3-1.8 - W, Hicks\William I. Hicks RSE Legal Description.docx



McMAHON ASSOCIATES, INC.  
885 Springdale Drive, Suite 300  
Exton, PA 19341  
p 610-594-9993 | f 610-594-9565

March 3, 2020

DESCRIPTION OF REQUIRED RIGHT-OF-WAY  
FOR LANDS OF WILLIAM I. HICKS  
(UPI #53-3-1.8)

All that certain required pieces of land situate in the Township of East Goshen, County of Chester, Commonwealth of Pennsylvania, Being part of land further described in an indenture dated the 7th day of January 1987 in Deed Book 591 Page 18 and recorded at West Chester in the Office for the Recorder of Deeds of Chester County, Pennsylvania. Bounded and described in accordance with a plan made by McMahon Associates, Inc., Exton, PA, entitled "PLAN OF REQUIRED RIGHT-OF-WAY FOR LANDS OF WILLIAM I. HICKS (UPI #53-3-1.8)" dated March 3, 2020, as follows to wit:

Beginning at a point in the northerly Legal Right-of-Way line of Paoli Pike (SR 2014) (40 feet wide), said point being distant the following three courses from the point of intersection of the westerly line of Grantor with the northerly Legal Right-of-Way line of Paoli Pike:

- a) Extending along the northerly Legal Right-of-Way line of Paoli Pike, North 61 degrees 13 minutes 02 seconds East, 104.71 feet to a point.
- b) Thence, continuing along the northerly Legal Right-of-Way line of Paoli Pike, South 29 degrees 46 minutes 58 seconds East, 10.00 feet to a point.
- c) Extending along the northerly Legal Right-of-Way line of Paoli Pike, North 60 degrees 13 minutes 21 seconds East, 350.01 feet to the point and place of beginning.

Thence, through portions of lands of Grantors, the following four courses:

- 1) North 29 degrees 46 minutes 39 seconds West, 40.00 feet to a point.
- 2) North 60 degrees 13 minutes 21 seconds East, 396.77 feet to a point.
- 3) South 31 degrees 17 minutes 42 seconds East, 40.01 feet to a point in the northerly Legal Right-of-Way line at Paoli Pike.
- 4) Thence, along the northerly Legal Right-of-Way line of Paoli Pike, South 60 degrees 13 minutes 21 seconds West, 397.83 feet to the point and place of beginning.

Containing 15892 square feet, or 0.365 acres.

H:\eng\61641720\Design\Right-of-Way\Take\Segment B\53-3-1.8 - W. Hicks\William I. Hicks ROW Legal Description.docx

# **Exhibit B**

**RETURN TO:**

Mark P. Thompson, Esq.  
LAMB MCERLANE PC  
24 E. Market Street  
P.O. Box 565  
West Chester, PA 19381-0565

UPI No. 53-3-1.9 (Part of)

**AMENDED NOTICE OF AGREEMENT REGARDING RELINQUISHMENT OF TITLE**

*(THIS AMENDED NOTICE OF AGREEMENT IS BEING RECORDED TO CORRECT AN ERROR  
IN THE RELINQUISHMENT PACKAGE FILED WITH THE RECORDER OF DEED WHICH INCLUDED A  
MISSING EXHIBIT AND INCORRECT DOCUMENTS.)*

THIS AMENDED NOTICE OF AGREEMENT REGARDING RELINQUISHMENT OF TITLE is made this \_\_\_ day of \_\_\_\_\_, 2026 by and between PETER M. HICKS and PHILIP HICKS ("Condemnees"), adult individuals, 1325 Paoli Pike, West Chester, County of Chester and Commonwealth of Pennsylvania and the TOWNSHIP OF EAST GOSHEN, 1580 Paoli Pike, West Chester, County of Chester and Commonwealth of Pennsylvania ("Condemnor").

**BACKGROUND**

A. On or around June 15, 2021, Condemnor began the process of condemning part of the property located at 1325 Paoli Pike, West Chester, Pennsylvania 19381, UPI No. 53-3-1.9 (the "Property"), owned by Condemnees, by adopting Resolution No. 2021-200.

B. On or around June 25, 2021, Condemnor filed a Declaration of Taking with the Chester County Court of Common Pleas.

C. On or around July 18, 2022, Condemnor and Condemnees entered into a Settlement Agreement and General Release.





COMMONWEALTH OF PENNSYLVANIA :  
 : SS  
COUNTY OF CHESTER :

I hereby certify that on this day, before me, an officer duly authorized in the Commonwealth of Pennsylvania and in Chester County to take acknowledgement, personally appeared PHILIP HICKS, known to me or satisfactorily proven to be the person who executed the foregoing instrument and acknowledged before me that he executed the same.

WITNESS my hand and official seal this \_\_\_\_\_ day of \_\_\_\_\_, 2026.

\_\_\_\_\_  
Notary Public

COMMONWEALTH OF PENNSYLVANIA :  
 : SS  
COUNTY OF CHESTER :

I hereby certify that on this day, before me, an officer duly authorized in the Commonwealth of Pennsylvania and in Chester County to take acknowledgement, personally appeared MICHELE TRUITT, VICE CHAIR OF THE BOARD OF SUPERVISORS OF THE TOWNSHIP OF EAST GOSHEN, known to me or satisfactorily proven to be the person who executed the foregoing instrument and acknowledged before me that he executed the same.

WITNESS my hand and official seal this \_\_\_\_\_ day of \_\_\_\_\_, 2026.

\_\_\_\_\_  
Notary Public

## **Exhibit “A”**

*Amended Notice of Agreement Regarding Relinquishment*

PETER/PHILIP  
CORRECTED

Prepared by, and after recording please return to:



Michael S. Gill, Esquire  
Buckley, Brion, McGuire & Morris LLP  
118 West Market Street  
West Chester, Pennsylvania 19382  
610.436.4400

25  
2

Part of UPI No. 53-3-1.9 ✓

**NOTICE OF AGREEMENT REGARDING RELINQUISHMENT OF TITLE**

IN RE  
CONDEMNATION BY  
TOWNSHIP OF EAST GOSHEN  
OF REAL PROPERTY  
LOCATED IN THE  
TOWNSHIP OF EAST GOSHEN,  
COUNTY OF CHESTER,  
COMMONWEALTH OF PENNSYLVANIA,  
FOR THE PURPOSE OF THAT CERTAIN  
PUBLIC RECREATION PROJECT KNOWN AS  
PAOLI PIKE TRAIL  
(PART OF TAX MAP PARCEL NO. 53-3-1.9)

COURT OF COMMON PLEAS  
CHESTER COUNTY,  
PENNSYLVANIA  
CIVIL ACTION  
NO. 2021-04834-RC

IN REM  
EMINENT DOMAIN

**FEE TITLE HOLDERS: PETER M. HICKS, AN ADULT INDIVIDUAL, AND  
PHILIP HICKS, AN ADULT INDIVIDUAL,  
AS THEIR INTERESTS MAY APPEAR**

This **NOTICE OF AGREEMENT REGARDING RELINQUISHMENT OF TITLE**  
is executed this 18<sup>th</sup> day of July, 2022, by Condemnor Township of East Goshen ("Condemnor")  
and Condemnees Peter M. Hicks and Philip Hicks (collectively, "Condemnees").

Condemnor and Condemnees are parties to that certain Settlement Agreement and General  
Release dated July 18, 2022, and regarding the above-captioned matter (the "Settlement  
Agreement").

Pursuant to the Settlement Agreement, and as mandated pursuant to Section 308.(e) of the  
Pennsylvania Eminent Domain Code, 26 Pa.C.S.A. § 308.(e), Condemnor and Condemnees hereby

DOC # 11936411 07/22/2022 11:27 AM  
Receipt #: 22-31735  
Rec Fee: \$82.50  
Chester County, Recorder of Deeds

11936411 B: 10916 P: 624 NOT  
07/22/2022 11:27 AM Page 1 of 26  
BUCKLEY BRION



provide notice to the world entire that all right, title, and interest which passed to Condemnor upon Condemnor's filing of the Declaration of Taking (a copy of which is attached hereto as Exhibit A) in this matter is, and for all intents and purposes whatsoever shall be deemed to be, re-vested in Condemnees, and all mortgages and other liens existing as of the date of such filing which were not thereafter discharges are, and for all intents and purposes whatsoever shall be deemed to be, reinstated.

IN WITNESS WHEREOF, Condemnor and Condemnees have executed this Notice of Agreement Regarding Relinquishment of Title the day and year first above written.

**THE TOWNSHIP OF EAST GOSHEN,**  
a Township of the Second Class

By: its Board of Supervisors,  
the duly elected and constituted  
governing body thereof

By: *Michele Truitt*  
Name: Michele Truitt  
Title: Chairwoman

Commonwealth of Pennsylvania - Notary Seal  
Derek J. Davis, Notary Public  
Chester County  
My commission expires November 29, 2024  
Commission number 1273275  
Member, Pennsylvania Association of Notaries

*Philip Hicks*  
PHILIP HICKS  
*Peter Hicks*  
PETER HICKS

Commonwealth of Pennsylvania - Notary Seal  
Derek J. Davis, Notary Public  
Chester County  
My commission expires November 29, 2024  
Commission number 1273275  
Member, Pennsylvania Association of Notaries

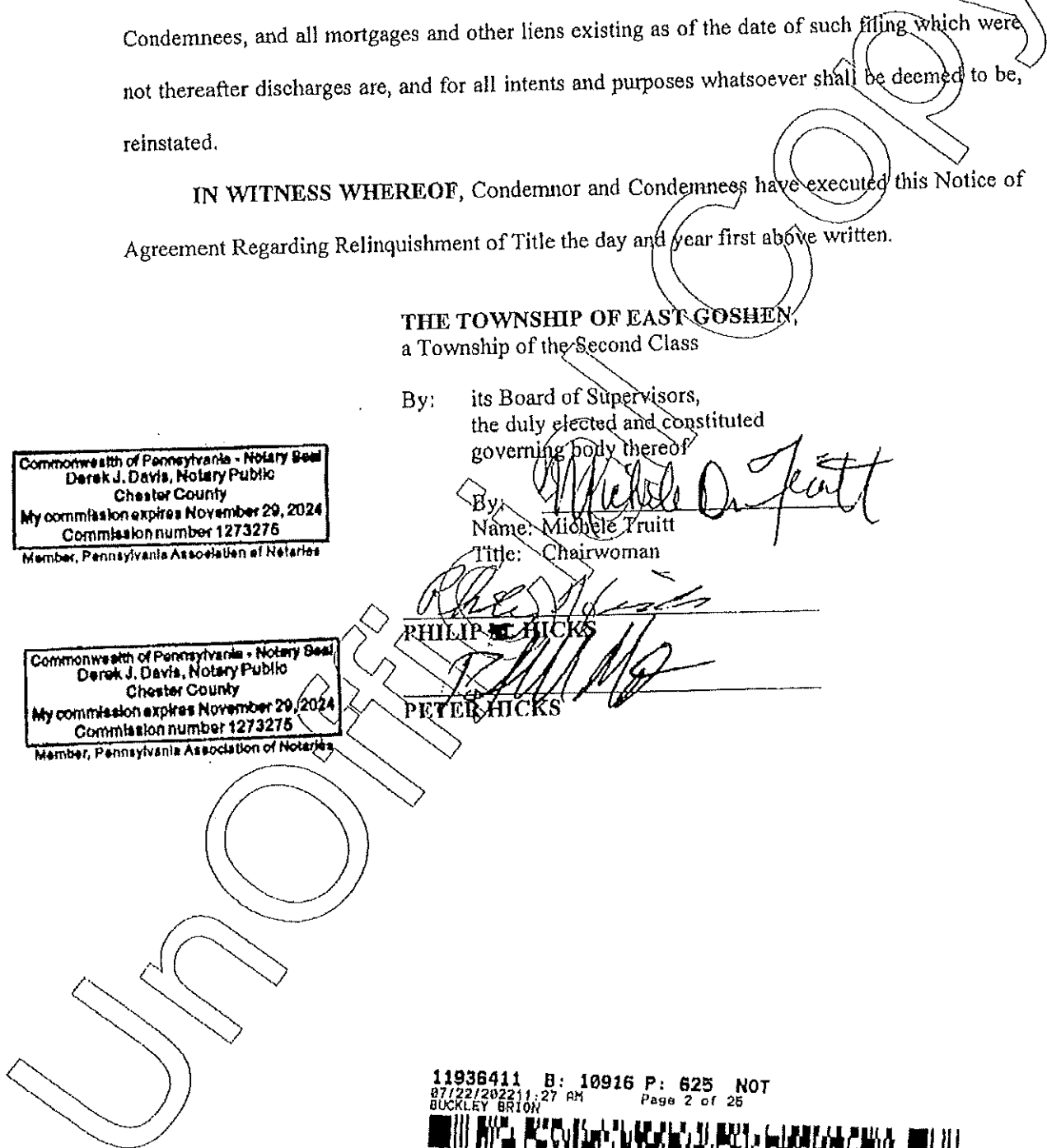



# EXHIBIT A

Unofficial Copy

11936411 B: 10916 P: 627 NOT  
07/22/2022 11:27 AM Page 4 of 25  
BUCKLEY BRION

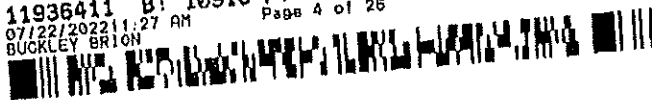

BUCKLEY, BRION,  
MCGUIRE & MORRIS LLP  
By: Kristin S. Camp, Esquire  
Attorney I.D. No. 74593  
By: Michael S. Gill, Esquire  
Attorney I.D. No. 86140  
118 West Market Street  
West Chester, Pennsylvania 19382  
610.436.4400

ATTORNEYS FOR CONDEMNOR  
TOWNSHIP OF EAST GOSHEN

IN RE  
CONDEMNATION BY  
TOWNSHIP OF EAST GOSHEN  
OF REAL PROPERTY  
LOCATED IN THE  
TOWNSHIP OF EAST GOSHEN,  
COUNTY OF CHESTER,  
COMMONWEALTH OF PENNSYLVANIA,  
FOR THE PURPOSE OF THAT CERTAIN  
PUBLIC RECREATION PROJECT KNOWN AS  
PAOLI PIKE TRAIL  
(PART OF TAX MAP PARCEL NO. 53-3-1.9)

COURT OF COMMON PLEAS  
CHESTER COUNTY,  
PENNSYLVANIA  
CIVIL ACTION NO. 2021-04834-RC  
IN REM  
EMINENT DOMAIN

FEE TITLE HOLDERS: PETER M. HICKS, AN ADULT INDIVIDUAL, AND  
PHILIP HICKS, AN ADULT INDIVIDUAL,  
AS THEIR INTERESTS MAY APPEAR

DECLARATION OF TAKING

The Township of East Goshen (the "Condemnor"), by and through its undersigned counsel, Kristin S. Camp, Esquire, Michael S. Gill, Esquire, and Buckley, Brion, McGuire & Morris LLP, files this Declaration of Taking as provided for in the Pennsylvania Eminent Domain Code of 2006, Act of May 4, 2006 P.L. 112, No. 34, § 1 (the "Code"), 26 PA.C.S.A § 302, and respectfully declares as follows:

i. Condemnor is the Township of East Goshen, a township of the second class organized and existing under and pursuant to the laws of the Commonwealth of Pennsylvania and having an address at 1580 Paoli Pike, West Chester, Pennsylvania 19380-6199.

2. Condemnees are Peter M. Hicks, an adult individual, and Philp Hicks, an adult individual, as their interests may appear.

3. The address for Condemnees as determined from the records of the Board of Assessment of the County of Chester is: 617 Airport Road, West Chester, Pennsylvania 19380.

4. Condemnor is authorized and empowered by Section 2201 of the Pennsylvania Second Class Township Code, 53 P.S. § 67201 to acquire "lands . . . by the exercise of the right of eminent domain for recreational purposes."

5. In order to complete the public recreation project known as the Paoli Pike Trail, Condemnor requires certain permanent and temporary easement interests in, on, over, to, and through certain portions of real property *situate* within Condemnor's jurisdictional limits and as more fully depicted on Exhibit A and as more fully described by metes and bounds (as to the required permanent easement) on Exhibit B, each attached hereto and incorporated herein by reference (the "Necessary Real Property Interests").

6. This Declaration of Taking was authorized by Resolution No. 2021-200 which the Board of Supervisors of Condemnor adopted on June 15, 2021. A copy of said Resolution is attached hereto as Exhibit C and is incorporated herein by reference. The record thereof may be examined at Condemnor's office at 1580 Paoli Pike, West Chester, Pennsylvania 19380-6199.

7. The purpose of the condemnation is to acquire property in connection with the construction and operation of that certain public recreation project known as Paoli Pike Trail.

8. The Necessary Real Property Interests are *situate* in the Township of East Goshen, County of Chester, Commonwealth of Pennsylvania. A plan of the Necessary Real Property Interests, sufficient for the identification thereof, is attached hereto as Exhibit A and is incorporated herein by reference. A metes and bounds descriptions of the required permanent



easement component of the Necessary Real Property Interests, sufficient for its identification, is as set forth at Exhibit B attached hereto and incorporated herein by reference.

9. On the same day on which Condemnor files this Declaration of Taking with the Office of the Prothonotary, Condemnor is filing with the Office of the Recorder of Deeds in and for Chester County a plan showing the Necessary Real Property Interests, all in accordance with Section 304 of the Code, 26 PA. C.S.A. § 304.

10. The nature of the title in and to the property hereby condemned is (A) 8,482 square feet, more or less, of required permanent sidewalk easement and (B) 7,011 square feet, more or less, of required temporary construction easement (the "Temporary Construction Easement"). The term of the Temporary Construction Easement will commence upon the date of Condemnor's entry onto the Necessary Real Property Interests and will endure for a period of thirty (30) months from that date. In the event that there are recoverable subsurface minerals (including gas and oil) within the area of the Necessary Real Property Interests, the subsurface mineral rights (including rights to gas and oil) in that area are hereby excepted and reserved from this condemnation; provided, however, that the right of later and adjacent support of the surface hereby condemned and any improvements now or hereafter erected thereon are included within the scope of this condemnation. Access for the removal of subsurface materials (including gas and oil) must be obtained from beyond the Necessary Real Property Interests, unless expressly permitted otherwise by Condemnor.

11. A plan showing the Necessary Real Property Interests may be inspected at the office of Condemnor's counsel, Buckley, Brion, McGuire & Morris LLP, 118 West Market Street, Suite 300, West Chester, Pennsylvania 19382, during regular business hours.

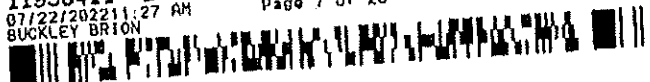

12. Just compensation for the condemnation of the Necessary Real Property Interests is secured by the power of taxation of Condemnor, whereupon the funds raised, or lawful to be so raised, are deemed pledged and made security for the payment of the damages as shall be determined by law.

Date: June 25, 2021

Respectfully submitted,

BUCKLEY, BRION, MCGUIRE & MORRIS LLP

By: Kristin S. Camp  
Kristin S. Camp, Esquire

By: Michael S. Gill  
Michael S. Gill, Esquire

Attorneys for Condemnor  
Township of East Goshen



CERTIFICATION OF COMPLIANCE

I hereby certify that this filing complies with the provisions of the *Public Access Policy of the Unified Judicial System of Pennsylvania: Case Records of the Appellate and Trial Courts* that require filing confidential information and documents differently than non-confidential information and documents.

Dated: June 25, 2021

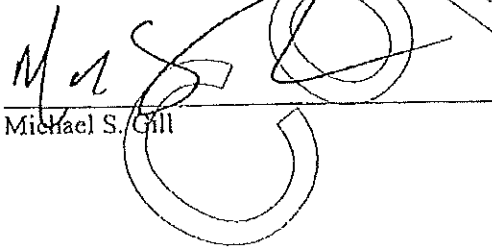
  
\_\_\_\_\_  
Michael S. Gill

Unofficial Copy



# EXHIBIT A

11936411 B: 10916 P: 633 NOT  
07/22/2022 11:27 AM Page 10 of 25  
BUCKLEY BRION





# EXHIBIT B

Unofficial Copy





McMAHON ASSOCIATES, INC.  
835 Springdale Drive, Suite 200  
Exton, PA 19341  
p 610-594-9993 | f 610-594-9565

June 14, 2021

DESCRIPTION OF REQUIRED SIDEWALK EASEMENT  
FOR LANDS OF PETER M. HICKS AND PHILIP HICKS  
(UPI #53-3-1.9)

All that certain required pieces of land situate in the Township of East Goshen, County of Chester, Commonwealth of Pennsylvania. Being part of land further described in an indenture dated the 7th day of October 2014 in Deed Book 9008 Page 2284 and recorded at West Chester in the Office for the Recorder of Deeds of Chester County, Pennsylvania. Bounded and described in accordance with a plan made by McMahon Associates, Inc., Exton, PA, entitled "PLAN OF REQUIRED SIDEWALK EASEMENT FOR LANDS OF PETER M. HICKS AND PHILIP HICKS (UPI #53-3-1.9)" June 14, 2021, as follows to wit;

Beginning at the point of intersection of the northerly Legal-Right-of-Way line of Paoli Pike (SR 2014) (72 feet wide), with the westerly line of Grantors; thence extending the following courses and distances:

- 1) Along the westerly line of Grantors, North 33 degrees 40 minutes 54 seconds West, 15.01 feet to a point.

Thence, through portions of lands of Grantors, the following five courses:

- 2) Along a line curving to the right having an arc length of 95.28 feet, a radius of 5,672.58 feet, a chord length of 95.28 feet, and a chord bearing of North 57 degrees 29 minutes 04 seconds East, to a point.
- 3) Thence, North 57 degrees 00 minutes 11 seconds East, 197.34 feet to a point.
- 4) Thence, North 57 degrees 18 minutes 06 seconds East, 70.64 feet to a point.
- 5) Thence, North 60 degrees 40 minutes 41 seconds East, 177.14 feet to a point in the easterly line of Grantors.
- 6) Thence along the easterly line of Grantors, South 31 degrees 49 minutes 54 seconds East, 17.95 feet to a point in the northerly Legal Right-of-Way line of Paoli Pike.

Thence, along the northerly Legal Right-of-Way line of Paoli Pike, the following four courses:

7) South 61 degrees 13 minutes 02 seconds West, 197.21 feet to a point.

8) Thence, along a line curving to the left having an arc length of 45.01 feet, a radius of 5,771.58 feet, a chord length of 45.01 feet, and a chord bearing of South 57 degrees 13 minutes 36 seconds West, to a point.

9) Thence, South 57 degrees 00 minutes 11 seconds West, 202.70 feet to a point.

10) Thence, along a line curving to the left having an arc length of 95.11 feet, a radius of 5,687.58 feet, a chord length of 95.10 feet, and a chord bearing of South 57 degrees 28 minutes 56 seconds West, to the point and place of beginning.

Containing 8482 square feet, or 0.195 acres.

E:\eng\1816117.10\Design\Right-of-Way\Takes\Segment B\53-3-1.9 - P. Hicks\Preparation Materials\Peter M. Hicks RSE Legal Description.docx

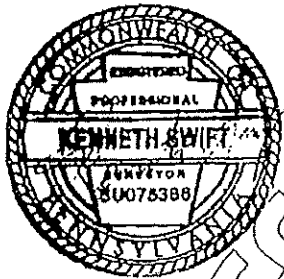

11936411 B: 10916 P: 637 NOT  
07/22/2022 11:27 AM Page 14 of 25  
BUCKLEY BRION



---

# EXHIBIT C

Unofficial Copy

11936411 B: 10916 P: 638 NOT  
07/22/2022 11:27 AM Page 15 of 25  
BUCKLEY BRION

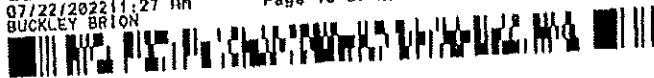

EAST GOSHEN TOWNSHIP  
CHESTER COUNTY, PENNSYLVANIA

RESOLUTION NO. 2021-200

RESOLUTION OF THE BOARD OF SUPERVISORS OF EAST GOSHEN TOWNSHIP AUTHORIZING THE ACQUISITION OF REAL PROPERTY INTERESTS SITUATE IN THE TOWNSHIP OF EAST GOSHEN, CHESTER COUNTY, PENNSYLVANIA BY PURCHASE OR CONDEMNATION FOR THE PURPOSE OF THE PUBLIC RECREATION PROJECT KNOWN AS THE PAOLI PIKE TRAIL.

WHEREAS, East Goshen Township (the "Township") is engaged in consultation and cooperation with the Commonwealth of Pennsylvania Department of Transportation with regard to that certain public recreation project known as the Paoli Pike Trail; and

WHEREAS, the Board of Supervisors of the Township (the "Board") is authorized and empowered pursuant to applicable law including, without limitation, Section 2201 of the Pennsylvania Second Class Township Code (53 P.S. § 67201), to acquire real property interests necessary for, and in furtherance of completion of, the Paoli Pike Trail; and

WHEREAS, in order to facilitate the Paoli Pike Trail, the Township requires certain permanent and temporary easement interests and rights-of-way or fee-simple ownership in, on, over, to, and through certain portions of real property *situate* within the Township and as more fully depicted on Exhibit A and as more fully described by metes and bounds (as to the required permanent easement) on Exhibit B, each attached hereto and incorporated herein by reference (the "Necessary Real Property Interests"); and

WHEREAS, the Necessary Real Property Interests include a permanent easement having an area measuring 8,482 square feet, more or less, identified on Exhibit A as "Required Sidewalk Easement" and a temporary construction easement having an area measuring 7,011 square feet, more or less, identified on Exhibit A as "Temporary Construction Easement;" and

WHEREAS, the Necessary Real Property Interests are, as of the date of this Resolution, part of the real property which is identified as Chester County Tax Map Parcel No. 53-3-1.9.

NOW, THEREFORE,

BE IT RESOLVED by the Board, and it is hereby resolved by authority of the same, that the acquisition of the Necessary Real Property Interests by purchase or condemnation according to law is authorized for, and in connection with, the public recreation project known as the Paoli Pike Trail; and

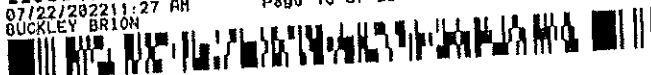

BE IT FURTHER RESOLVED by the Board, and it is hereby resolved by authority of the same, that the Necessary Real Property Interests for the public recreation project known as the Paoli Pike Trail shall be acquired by the Township by purchase or condemnation under the provisions of the Acts of Assembly, as more fully set forth in the Resolution; and

BE IT FURTHER RESOLVED by the Board, and it is hereby resolved by authority of the same, that the Township Manager and the Township Solicitor are authorized and directed to take any and all steps which they, in their discretion, deem necessary and proper and in the best interests of the Township to effectuate this Resolution including, without limitation, the filing of one or more Declaration(s) of Taking under and pursuant to the Pennsylvania Eminent Domain Code, 26 Pa.C.S.A. § 101 *et seq.*

ADOPTED by the Board of Supervisors of East Goshen Township this 15<sup>th</sup> day of June, 2021.

ATTEST:

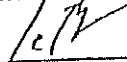
  
\_\_\_\_\_  
Louis F. Smith, Secretary

EAST GOSHEN TOWNSHIP  
BOARD OF SUPERVISORS

  
\_\_\_\_\_  
David B. Shuey, Chairman

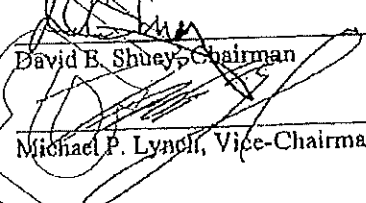
  
\_\_\_\_\_  
Michael P. Lynell, Vice-Chairman

\_\_\_\_\_  
John Hertzog, Member

\_\_\_\_\_  
Michelle Truitt, Member

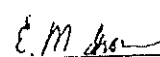
  
\_\_\_\_\_  
E. Martin Shane, Member



# EXHIBIT A

Unofficial Copy

11936411 B: 10916 P: 641 NOT  
07/22/2022 11:27 AM Page 18 of 25  
BUCKLEY BRION

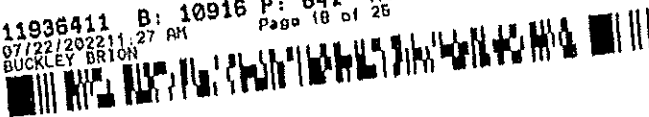



**EXHIBIT B**

UnOfficial Copy





McMAHON ASSOCIATES, INC.  
835 Springdale Drive, Suite 200  
Exton, PA 19341  
p 610-594-3295 | f 610-394-3365

June 14, 2021

DESCRIPTION OF REQUIRED SIDEWALK EASEMENT  
FOR LANDS OF PETER M. HICKS AND PHILIP HICKS  
(UPI #53-3-1.9)

All that certain required pieces of land situate in the Township of East Gosport, County of Chester, Commonwealth of Pennsylvania. Being part of land further described in an indenture dated the 7th day of October 2014 in Deed Book 9008 Page 2284 and recorded at West Chester in the Office for the Recorder of Deeds of Chester County, Pennsylvania. Bounded and described in accordance with a plan made by McMahon Associates, Inc., Exton, PA, entitled "PLAN OF REQUIRED SIDEWALK EASEMENT FOR LANDS OF PETER M. HICKS AND PHILIP HICKS (UPI #53-3-1.9)" June 14, 2021, as follows to wit;

Beginning at the point of intersection of the northerly Legal Right-of-Way line of Paoli Pike (SR 2014) (72 feet wide), with the westerly line of Grantors, thence extending the following courses and distances:

- 1) Along the westerly line of Grantors, North 33 degrees 40 minutes 54 seconds West, 15.01 feet to a point.

Thence, through portions of lands of Grantors, the following five courses:

- 2) Along a line curving to the right having an arc length of 95.28 feet, a radius of 5,672.58 feet, a chord length of 95.28 feet, and a chord bearing of North 57 degrees 29 minutes 04 seconds East, to a point.
- 3) Thence, North 57 degrees 00 minutes 11 seconds East, 197.34 feet to a point.
- 4) Thence, North 57 degrees 18 minutes 06 seconds East, 70.64 feet to a point.
- 5) Thence, North 60 degrees 40 minutes 41 seconds East, 177.14 feet to a point in the easterly line of Grantors.
- 6) Thence along the easterly line of Grantors, South 31 degrees 49 minutes 54 seconds East, 17.95 feet to a point in the northerly Legal Right-of-Way line of Paoli Pike.

Thence, along the northerly Legal Right-of-Way line of Paoli Pike, the following four courses:

- 7) South 61 degrees 13 minutes 02 seconds West, 197.21 feet to a point.
- 8) Thence, along a line curving to the left having an arc length of 45.01 feet, a radius of 5,771.58 feet, a chord length of 45.01 feet, and a chord bearing of South 57 degrees 13 minutes 36 seconds West, to a point.
- 9) Thence, South 57 degrees 00 minutes 11 seconds West, 202.70 feet to a point.
- 10) Thence, along a line curving to the left having an arc length of 95.11 feet, a radius of 5,687.58 feet, a chord length of 95.10 feet, and a chord bearing of South 57 degrees 28 minutes 56 seconds West, to the point and place of beginning.

Containing 8482 square feet, or 0.195 acres.

\\ms10161120\Drawings\Right-of-Way\Tables\Segment B\SS-313 - P. Buckle\Property\Buckley\Buckley, M. HCU\RSR Legal\Descrpt\Bord.docx



# Memorandum

---



East Goshen Township  
1580 Paoli Pike  
West Chester, PA 19380  
610-692-7171 ext. 3103  
[kkrause@eastgoshen.org](mailto:kkrause@eastgoshen.org)

Date: May 28, 2026  
To: Board of Supervisors  
From: Kelly A. Krause, Zoning Officer  
Re: **Zoning Hearing Board Application No. Z26-02 (Dimensional Variance)**  
**17 Treemont Drive, Malvern/Sheffield**  
**Chester Co. UPI #53-2F-18**

---

A Zoning Hearing Board application has been submitted by Erin & Bryan Sheffield, owners of 17 Treemont Drive, Malvern, who seek relief from the provisions of §240-9.G to allow the construction of a 769 square foot deck which will encroach into the required 20' side yard setback by 4' (providing a 16' setback), and by 4' 7" (providing a 15' 5" setback) into each respective side yard. The property is located within the R-2 Low Density Residential Zoning District.

The property is legally nonconforming in respect to minimum lot width at the building line, providing approximately 108 feet where 150 feet is the minimum required, and the rear portion of the lot is within the 100-year floodplain.

On Tuesday, May 26, 2026, the Township Planning Commission voted in support of the variance request.

**The following information is attached:**

1. Zoning Hearing Board Application, dated May 8, 2026 with revision (2 pages)
2. Site plan drawn by Fisher Brothers Exteriors, dated May 4, 2026
3. Drawing of proposed deck
4. Renderings of proposed deck
5. Photos of the property
6. Measurement of Grade narrative with supporting photos
7. ChescoViews Tax Map with floodplain layer overlay

**Draft Motion:**

Mr. Chairman, I move that we \_\_\_\_\_ (support/take no action) on the dimensional variance to construct a deck which will encroach into each required 20' side yard by 4', and 4' 7", respectively.

**RECEIVED**  
By kkrause at 11:50 am, May 14, 2026

**EAST GOSHEN TOWNSHIP  
ZONING HEARING BOARD APPLICATION**

1580 PAOLI PIKE WEST CHESTER, PA 19380-6199  
PHONE (610)-692-7171 FAX (610)-692-8950

Name of Applicant: Erin Sheffield  
Applicant Address: 17 Treemont Drive  
Malvern PA 19355  
Telephone Number: 646.573.2640 Email: erisheffield@gmail.com  
Email Address: \_\_\_\_\_  
Property Address: 17 Treemont Drive, Malvern PA 19355  
\_\_\_\_\_  
Tax Parcel Number: 53-2F-18 Zoning District: R-2 Acreage: 1 acre

**Purpose of Application (check one)**

- Variance ( Type:  Use Variance  Dimensional Variance)  
 Special Exception  
 Appeal determination of the Zoning Officer  
 Other \_\_\_\_\_

**Sections of Zoning Ordinance in which relief is sought:**

240-9-G side yard set back

**Description of the Zoning Relief requested and the future use of the property:**

4' on one side and 4'7" on the other side

**Description of the Hardship:**

The requested relief is needed to address a safety and accessibility hardship. The grade of the side yard causes the existing slate steps to erode annually creating a hazardous condition. Replacing them with a platform to allow turn around at the door and wood steps and a handrail is necessary for safe, reliable use. This is the minimum improvement to ensure stable access to the backyard for aging parents and all.

We hereby acknowledge that we have read this application and state that the above is correct and agree to comply with all provisions of the East Goshen Township Zoning Ordinance applicable to this project and property.

Erin Sheffield 5/8/26  
Signature of Applicant Date

**\*Please review the formal application and review procedures on page three.**

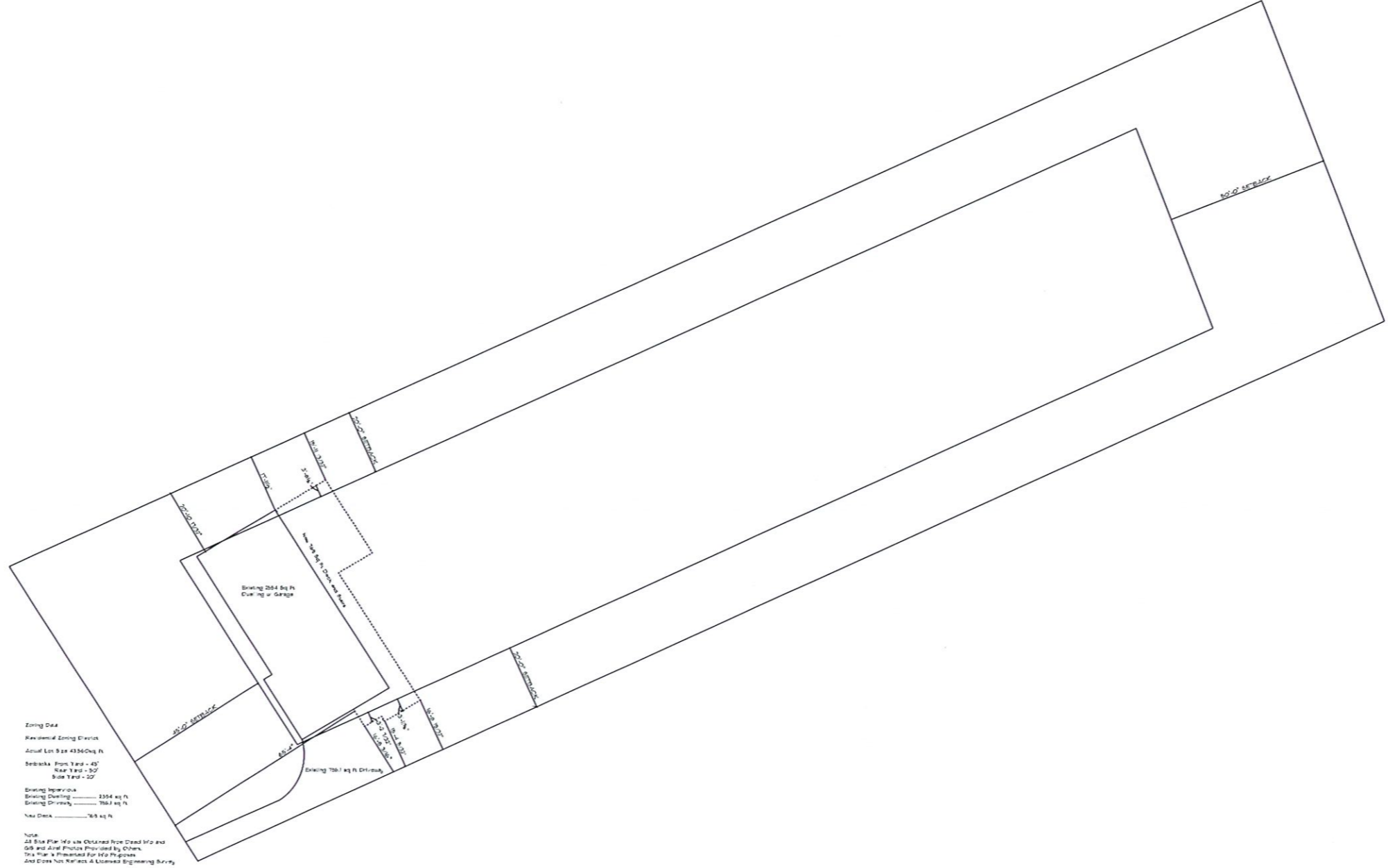

Zoning Data  
 Residential Zoning District  
 Actual Lot Size 4334 Sq Ft  
 Setbacks: Front Yard - 45'  
 Rear Yard - 30'  
 Side Yard - 25'  
 Existing Improvements  
 Existing Driveway - 2354 sq ft  
 Existing Driveway - 1567 sq ft  
 New Deck - 768 sq ft

**SITE PLAN**  
 SCALE: 1" = 40'-0"

Note:  
 All Site Plan Information Obtained From Deed Info and  
 LPA and Aerial Photos Provided by Client  
 This Plan is Intended For Info Purposes  
 And Does Not Replace A Licensed Engineering Survey

**Erin Sheffield**  
 17 Treemont Drive  
 Malvern  
 Pennsylvania  
 19355  
 PHONE:  
 FAX:  
 MOBILE:

DRAWN BY: D.L.F.  
 SCALE: 1" = 40'-0"  
 DATE: Monday, May 4, 2026  
 PAGE: **6/6**  
 Site Plan

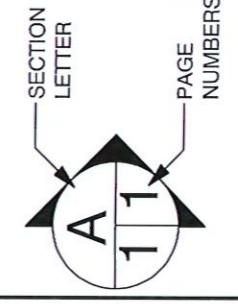

**FISHER BROTHERS EXTERIORS**  
 1016 BRACKBILL ROAD  
 GAP PA 17527

- 2
- 205' 4"
- 4.69 ft<sup>2</sup>
- d, Pine
- d, Pine
- d, Pine
- W...
- W...
- d, Pine
- f 6"x1"
- f 6"x1"
- 10"x2"
- f 1"x6"
- f 6"x6"

Library Smart Data



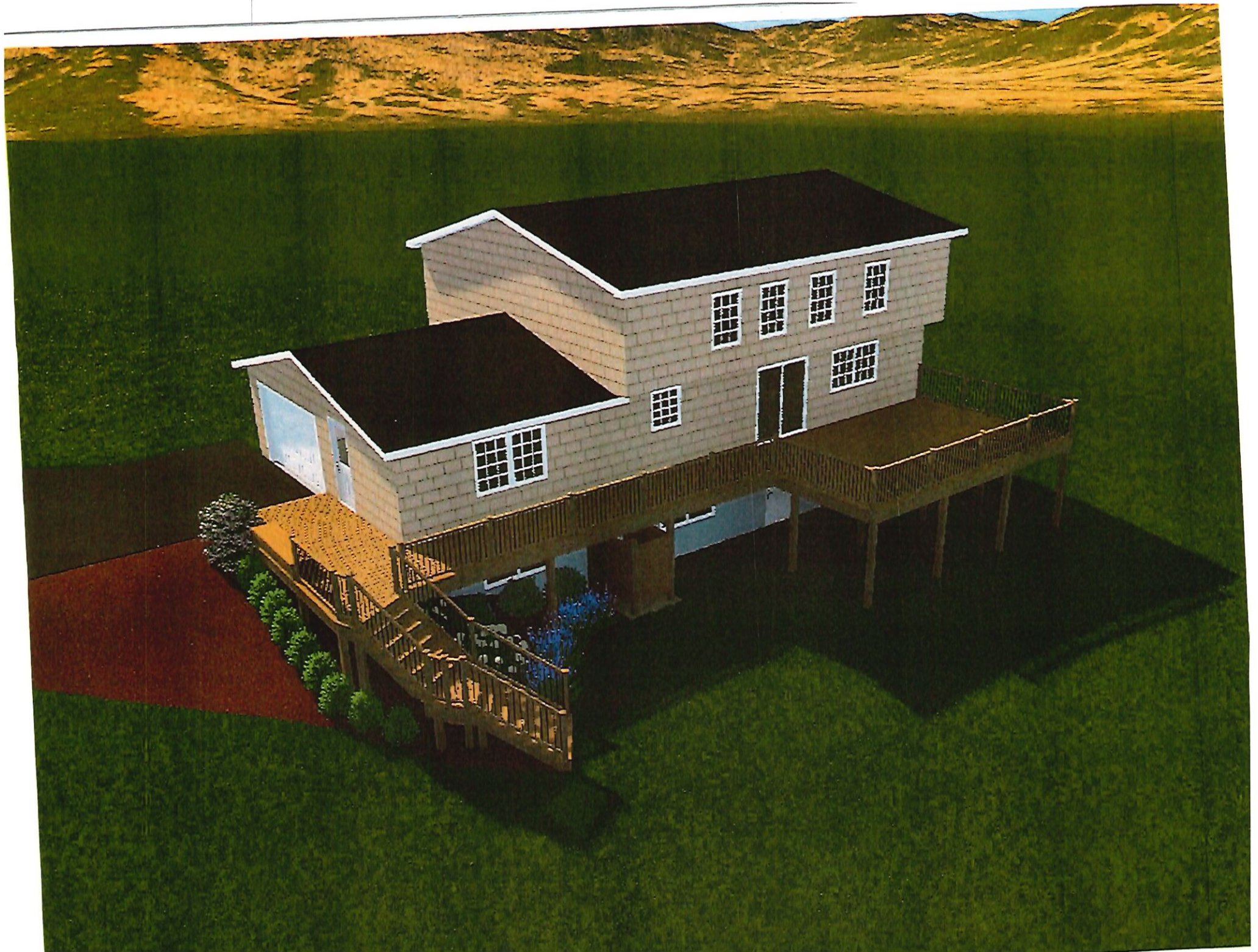







Measurement of Grade, supported by pictures

Sheffield property

17 Treemont Drive, Malvern PA

The property has a measured grade change of approximately 67 inches over a horizontal distance of 248 inches, resulting in a slope of approximately 27%.

This steep grade makes safe and reasonable access between the house and yard impractical without the use of stairs and a small platform. The proposed encroachment represents the minimum necessary to address this unique physical condition.